

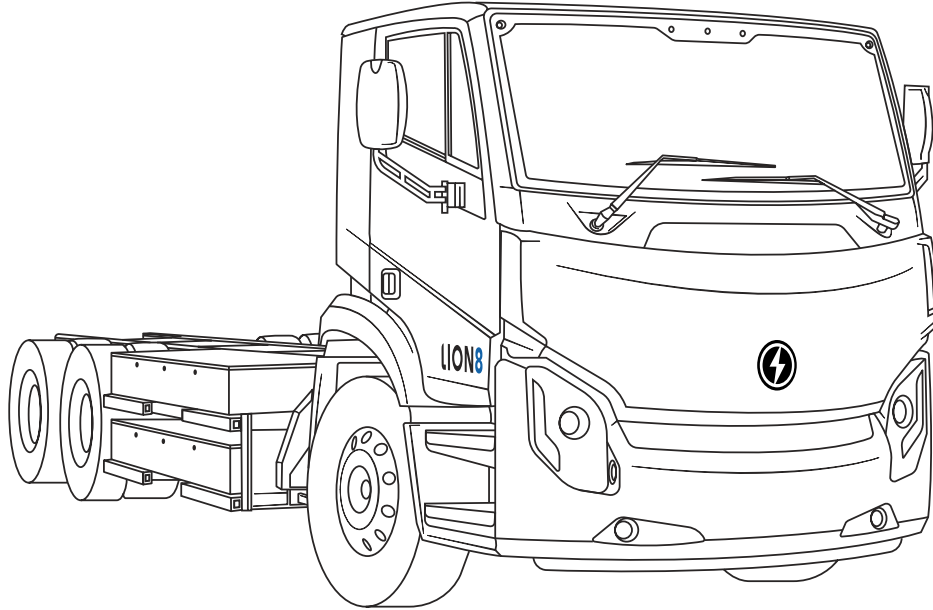

Emergency Response Guide



This guide is intended for first responders and certified rescuers. high-voltage batteries are the only energy source for the propulsion of the Lion8. Always act as if the high-voltage system is activated. the high-voltage system might be active even when the vehicle emits no sound.

LION8

LEGAL NOTICE

The information contained in this document is subject to change without notice. This document is intended for first responders and certified rescuers. No part of this document may be reproduced or transmitted in any form without the prior written permission of *The Lion Electric Company*.

The Lion Electric Company cannot be held liable for any errors in this document, or for any damages that may result from the use of this document or the information contained.

Intellectual property rights related to this document and the product described are exclusive to *The Lion Electric Company* and are protected by applicable intellectual property legislation.

Copyright © The Lion Electric Company 2023.
All rights reserved.

LION8 Emergency Response Guide - 2024/09/26

Legal Notice 2

CONTENT 3

VEHICLE IDENTIFICATION 5

Identification 5

Logos 5

TURNING OFF THE VEHICLE 6

Turning off the the vehicle 6

High-voltage hold (if equipped) 7

ABOUT THE BATTERIES 8

About the batteries 8

Characteristics of high-voltage batteries 8

Boosting the low-voltage batteries 8

Charging one of the two batteries: 9

Charging both 12 V batteries that are connected
in series: 9

High-voltage battery locations 10

DISABLING THE HIGH-VOLTAGE BATTERIES. . . . 11

Orange high-voltage cables 11

High-voltage equipment warnings 11

Warning labels 12

High-voltage safety disconnect 13

In case of emergency 13

CRASH SENSOR 14

Crash sensor 14

To reset an impact detector: 14

FIRE AND WATER IMMERSION 15

Fire extinguishment of high-voltage batteries 15

Submerged vehicle 15

UNDER THE HOOD 16

Capot 16

To open the hood 16

To close the hood 17

// CONTENT

CONSUMABLES	18	TOWING THE VEHICLE	21
Fluid tank locations	18	Manual parking brake release	21
Auxiliary fuel heating tank location (if equipped)	19	Towing the vehicle	23
		Front lift towing under 35 mph (50 km/h)	23
LIFTING THE VEHICLE	20	Front towing equipment capacity	24
Jacking the vehicle	20	Best practices to install trailer hitch	24
		Removing wheel axle half shaft	26
		Tow hooks	27
		Towing in case of electrical breakdown	30

// VEHICLE IDENTIFICATION

Identification

The **LION8** can be identified by the Lion Electric logo located at the center front of the hood.

The logo can also be found on the body of the vehicle and on several chassis components.

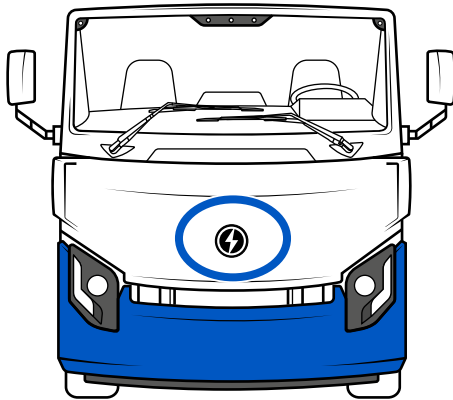

Figure 1 - Front view of the **LION8**

Logos

The following logos can be used to identify the **LION8**.



LION ELECTRIC

Figure 2 - Lion Electric logo

LION8

Figure 3 - **LION8** logo

// TURNING OFF THE VEHICLE

Turning off the the vehicle

To turn off the **LION8**:

1. Immobilize the vehicle using the service brake.
2. Apply the parking brake by pulling the yellow knob (**Figure 4**) on the dashboard.
3. Put the vehicle in neutral by pressing the top part of the "N" pushbutton of the gear selector (**Figure 5**).
4. Shut off all electrical loads (radio, air conditioning, electric heating) .
5. Turn the starter switch to the "OFF" position (**Figure 6**).

The vehicle's high-voltage circuit is turned off.



Figure 4 - Parking brake knob (yellow)

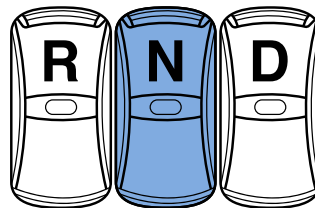

Figure 5 - Gear selector

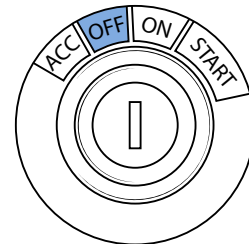

Figure 6 - Starter switch

// TURNING OFF THE VEHICLE

High-voltage hold (if equipped)

If equipped, the high-voltage hold function allows you to remove the key from the starter switch and exit the vehicle while leaving the high-voltage system active.

To turn off the high-voltage hold, press the button **(Figure 7)** located on the steering column, below the starter switch.

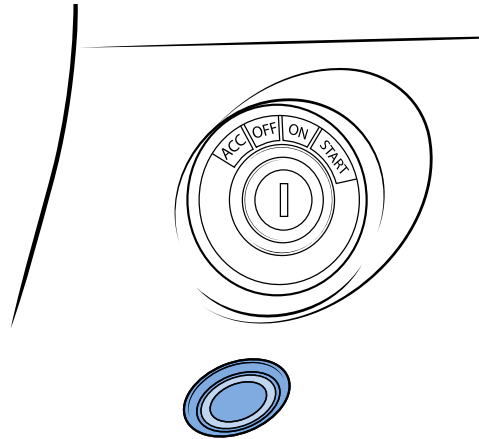

Figure 7 - High-voltage hold button (if equipped)

// ABOUT THE BATTERIES

About the batteries

The **LION8** uses two types of batteries that provide low and high voltage.

Low voltage	High voltage
The two 12 V batteries supply power to various systems which operate at low voltage such as headlights and windshield wipers.	The high-voltage battery packs supply power to the electric motor and charge the 12 V batteries.

Table 1 - Types of batteries

Characteristics of high-voltage batteries

The **LION8** is equipped with six BMW battery packs of 42.24 kWh each for a total capacity of 253.44 kWh.

Boosting the low-voltage batteries

To boost low-voltage batteries, it is recommended to use a battery charger rather than another vehicle. However, in an emergency, another vehicle can be used to boost the batteries. But be advised that this is damaging for the batteries.



At all costs, avoid connecting the negative jumper cable to the vehicle's frame because the two low-voltage batteries are connected in series.

// ABOUT THE BATTERIES

Charging one of the two batteries:

1. Disconnect the wires that connect the two 12 V batteries.
2. Using a 12 V charger, connect the charger's negative jumper cable to the negative pole of the battery to be charged.
3. Connect the charger's positive jumper cable to the positive pole of the battery to be charged.
4. Turn on the battery charger (or start the vehicle engine for jump starting) and let it run for a few minutes to charge the vehicle's batteries.

Once the high voltage can be switched on, the converters can be used and the clamps can be removed. However, it's strongly recommended that you leave the converters running for 30 minutes to ensure that the batteries are fully charged. The vehicle can then be driven immediately.

Charging both 12 V batteries that are connected in series:

1. Using a 24 V charger, connect the charger's negative cable to negative pole of the first 12 V battery.
2. Connect the charger's positive cable to the positive pole of the second battery.
3. Activate the battery charger (or start the vehicle engine for jump starting) and let it run for a few minutes to charge the vehicle's batteries.

Once the high voltage can be switched on, the converters can be used and the clamps removed. However, it's strongly recommended that you leave the converters running for 30 minutes to ensure that the batteries are fully charged. The vehicle can then be driven immediately.

// ABOUT THE BATTERIES

High-voltage battery locations

The **LION8** is equipped with six high-voltage battery packs.

The battery packs are located as illustrated in **Figure 8**.

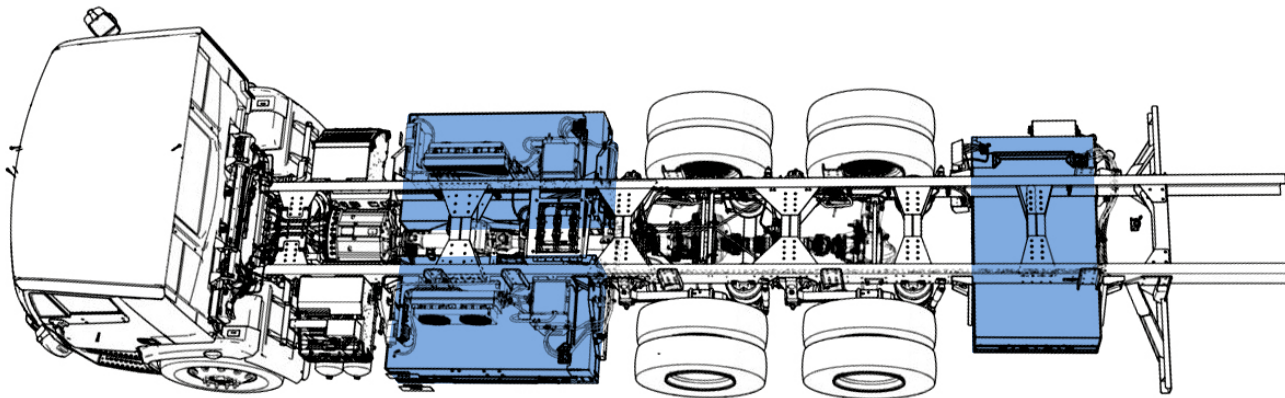

Figure 8 - High-voltage battery locations

// DISABLING THE HIGH-VOLTAGE BATTERIES

Orange high-voltage cables



HAZARD WARNING



High-voltage cables are orange. If an accident occurs, do not touch any high-voltage wiring, connectors, connected components or any metal surface

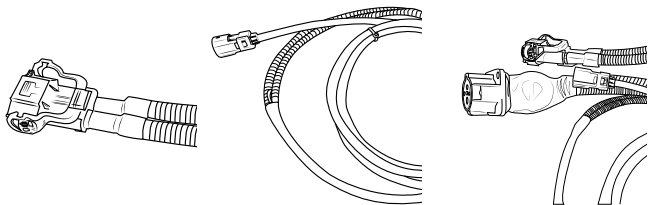

Figure 9 - Examples of orange high-voltage cables

High-voltage equipment warnings

Vehicles containing high-voltage equipment are equipped with warning labels. Extra attention to the special characteristics of high-voltage technology should be given.

// DISABLING THE HIGH-VOLTAGE BATTERIES

Warning labels









Label	Meaning	Label	Meaning
	DO NOT turn on the starter switch. Work on high-voltage systems in progress.		CAUTION! High-voltage battery Incorrect handling may cause injury High voltage Risk of explosion Risk of chemical burns and eye injuries
	CAUTION! Hazardous voltage		CAUTION! High voltage The voltage behind this panel is potentially fatal. Access is restricted to qualified personnel.
	CAUTION! High-voltage parts Before working on the vehicle, follow the procedure described in the <i>High-voltage safety disconnect</i> section of this document.		Battery specifications You are in the presence of hazardous voltage.
	HAZARDOUS VOLTAGE! Risk of electrocution Shut off high-voltage equipment.		Danger High voltage Certain components must be disconnected before servicing. Please see the <i>High-voltage safety disconnect</i> section in this manual.

Table 2 – High-voltage equipment labels

// DISABLING THE HIGH-VOLTAGE BATTERIES

High-voltage safety disconnect

The **LION8** is equipped with a battery disconnect switch as an additional safety feature to quickly shut off the high-voltage circuits. The battery disconnect switch is located in the accessory compartment behind the left front wheel (**Figure 10**). It can be used in case of an emergency or for maintenance purposes.

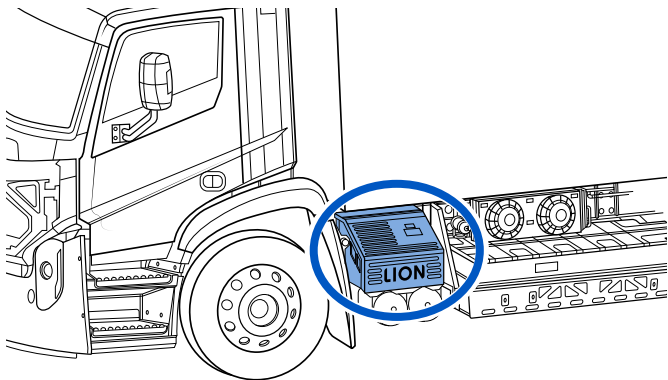

Figure 10 – Battery disconnect switch location

In case of emergency

1. Check to make sure that the vehicle is not charging and that the starter switch is turned off. Remove the key from the starter switch.
2. Turn off the battery disconnect switch to shut off the low-voltage power supply (**Figure 11 no. 1**).
3. Double cut the low-voltage battery cable located in the accessories compartment (**Figure 11 no. 2**).

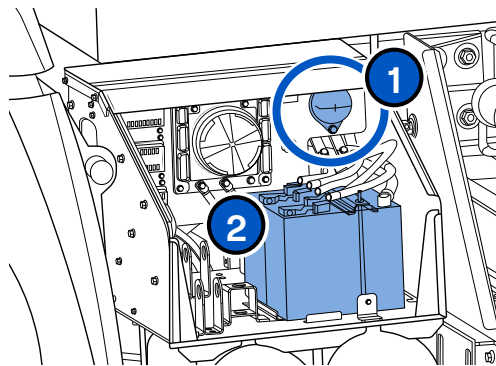

Figure 11 – Battery disconnect switch

// CRASH SENSOR

Crash sensor

The **LION8** is equipped with an impact detector that instantly shuts down high-voltage circuits when it measures an impact of between 8 g and 30 g.

To reset an impact detector:

1. Open the hood.
2. Locate the impact detector on the firewall and press the button (**Figures 12 and 13**).

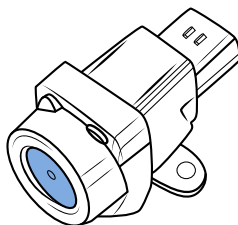

Figure 12 - Impact detector

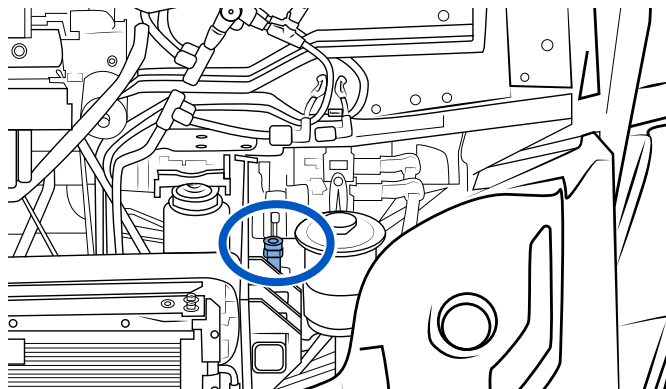

Figure 13 - Location of impact detector

// FIRE AND WATER IMMERSION

Fire extinguishment of high-voltage batteries

If there is a crack in the batteries due to an impact, an inflammable and corrosive electrolyte solution may leak.

If there is a fire in the batteries, use a lot of water to cool down the batteries or CO2. The batteries will not explode.

Depending on the availability, other extinguishing agents (fire extinguishing foam, extinguishing powder) may also be used.

As common in firefighting, complete personal protective equipment (PPE) including self-contained breathing apparatus (SCBA) must be used.

If there a fire that is not emerging from the high-voltage batteries, it can be treated using typical vehicle firefighting procedures.

Submerged vehicle

A **LION8** that is submerged in water will not present the risk of electrocution since the high-voltage batteries are isolated from the vehicle chassis.

Treat a partially or fully submerged as any other vehicle and use the appropriate personal protective equipment (PPE).

Once the vehicle is removed from water, disable the high voltage using the procedure listed in this manual (**see page 13**).



If the vehicle has been immersed in water, turn the battery disconnect switch to the "OFF" position and contact your Lion Service Centre for instructions.

If the vehicle is parked indoors, it must be towed outside and parked away from buildings and other vehicles.

// UNDER THE HOOD

Capot

The **LION8** electrical components can be accessed by opening the hood.

To open the hood:

1. Stand in front of the vehicle and locate the release latches (**Figure 14**) on each side of the front of the hood.
2. Pull both levers at the same time.

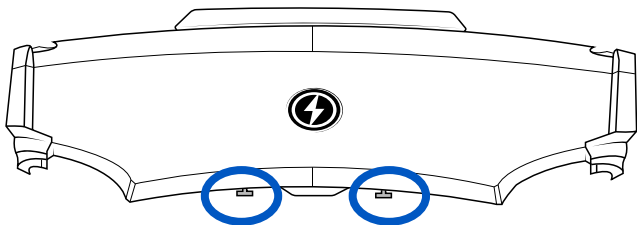

Figure 14 - Location of hood latches

3. Slowly lift the hood and locate the handle located in the center, at the far edge of the hood (**Figure 15**).
4. Use the handle to lift the hood.

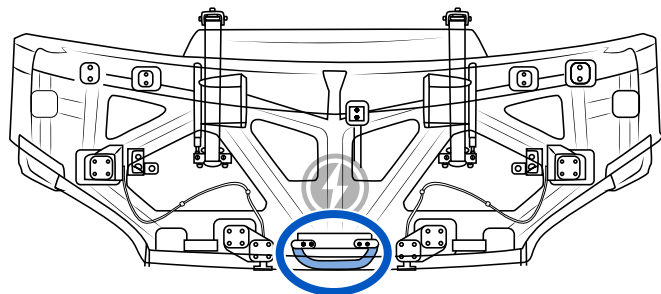

Figure 15 - Location of handle under the hood

5. Push on both arms of the safety mechanism to lock the hood in the open position (**Figure 16**).

The hood is open and securely locked.

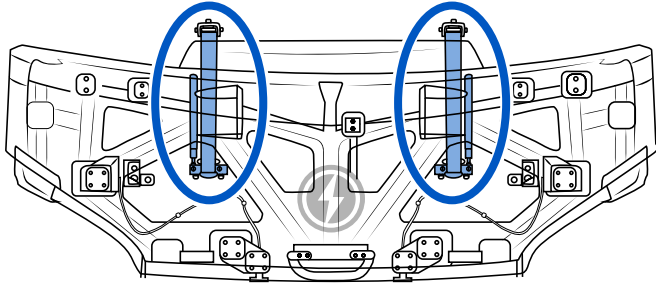

Figure 16 - Location of hood safety mechanism

To close the hood:

1. Grab the center handle, at the edge of the hood, and push the hood gently upwards while pulling on both arms of the safety mechanism to unlock them.
2. Lower the hood until it latches.

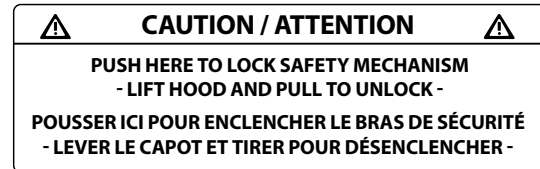

Figure 17 - Safety label under the hood

// CONSUMABLES

Fluid tank locations

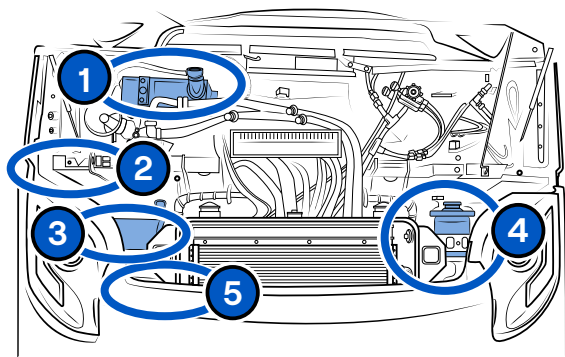

Figure 18 - Under the hood of the LION8

N°	Description
1	Cabin heater surge tank
2	Cabin tilt mechanism hydraulic pump tank
3	Motor coolant system fluid tank
4	Power steering fluid tank
5	Windshield washer fluid tank

Tableau 3 - LION8 fluid tank locations

Auxiliary fuel heating tank location (if equipped)

The **LION8** can be equipped with an auxiliary fuel heater. The diesel tank holds 43.9 gallons (15 liters) and is located behind the right front wheel. Note that both options may be combined.

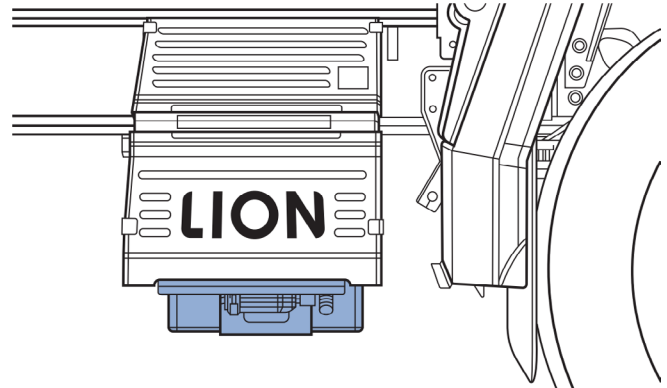

Figure 19 - Location of diesel tank for auxiliary fuel heater

// LIFTING THE VEHICLE

Jacking the vehicle

Jack points

Proper jacking procedures and basic safety measures must be observed to ensure the safety of personnel while working under the truck. Always check the serviceability of any lifting equipment prior to use.

Ensure that the lifting equipment is of sufficient strength to handle the vehicle, and that the surface provides the necessary firmness to support the weight of the vehicle concentrated on the footprint of the jack. Never move under a truck supported only by a hydraulic jack.

1. Park the truck on a flat, level surface of sufficient firmness to support the jack.
2. Chock the wheels in both directions.
3. Use only certified jacks and stands of sufficient capacity to support the vehicle. Following the jack manufacturer's recommendations, place the jack securely under the axle at the spring or suspension beam, nearest the tire/wheel to be repaired. Jack the truck only to the height necessary to service.
4. Support the truck with blocks or jack stands under the frame rails.

Manual parking brake release

If all of the air has been evacuated from the pneumatic system or there is an air leak from a brake actuator, it is possible to release the parking brakes by manually compressing (caging) the spring brake actuator. Before manually releasing parking brakes, chock the wheels to prevent the vehicle from moving.

To manually release the spring brake:

1. Remove the dust plug from the parking brake chamber.
2. Remove the release nut and washer from the release bolt

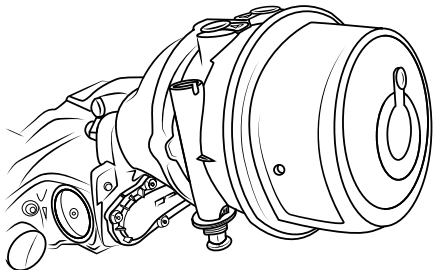

Figure 20 - Frein de stationnement de l'essieu arrière

3. Slide the release bolt out of the holder.
4. Insert the compression screw assembly through the opening in the rear of the spring chamber.
5. Turn the release bolt a quarter turn clockwise.

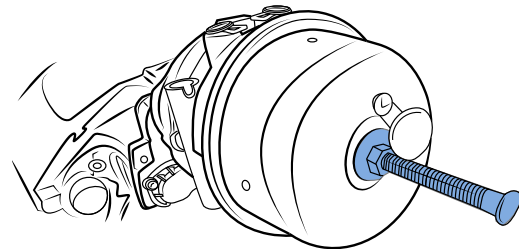

Figure 21 - Desserrage du frein de stationnement de l'essieu arrière

// REMORQUAGE

6. Using a wrench, turn the release bolt assembly nut until the compression spring is 90–95 % caged.
7. Check to make sure the pushrod is retracting.

The spring brake is now released mechanically.

If all of the air has been evacuated from the pneumatic system or there is an air leak from a brake actuator, it is possible to release the parking brakes by manually compressing (caging) the spring brake actuator. Before manually releasing parking brakes, chock the wheels to prevent the vehicle from moving

To move the vehicle when the parking brakes have been manually applied, use a tow truck.



WARNING



Always chock the wheels before starting this procedure: when a parking brake spring is manually caged, the parking brake will no longer operate.

Towing the vehicle



WARNING



This vehicle must be towed by lifting the rear. Do not forget to lock the steering wheel.

Front lift towing under 35 mph (50 km/h)

If the truck cannot be towed from behind, front towing must be limited to 35 mph (50 km/h). In case of emergency, you can tow from the front axle while leaving the rear wheels in contact with the ground. We do not recommend towing the vehicle this way for long distances and you cannot exceed 35 mph (50 km/h).

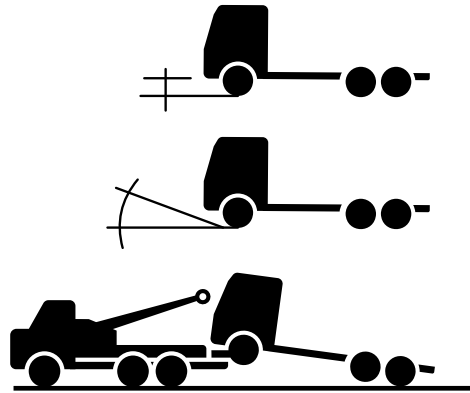

Figure 22 - Front lift towing

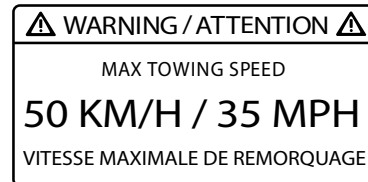

Figure 23 - Towing safety warning

// TOWING THE VEHICLE

Front towing equipment capacity

A vehicle's maximum towing capacity depends on the steering and towing angle. These are listed in **Table 4** and are calculated for two hitches working simultaneously.

Best practices to install trailer hitch



WARNING



The data in the table above assumes that the constraints are shared equally between the two hitches. Severe damage to the vehicle can occur if the assembly isn't properly secured.

If the vehicle gets stuck or goes off the road, use the towing equipment with extreme caution and observe capacity limits. Damage to the axle, suspension or hitch can occur if the vehicle gets stuck, even if the pulling force at the hitch is less than the maximum capacity.

Direction of the traction exerted	Maximum capacity	
	kg	lb
Straight towards the front	36,287	80,000
Up front in a V	18,144	40,000
Vertical straight	6,622	14,600
Horizontal straight on the side	4,082	9,000
45 degrees up or down	9,072	20,000
45 degrees straight on the side	5,443	12,000

Table 4 - Towing capacity by direction of pull

// TOWING THE VEHICLE

For safe towing, we recommend the following:

- Use double chains or ropes to distribute the load evenly between both hitches (see either recovery option in **Figure 24**).
- Never run a single chain or cable through both hitches.
- Use a spreader or stabilizer bar to distribute the load between the two hooks (**Figure 24 no. 1**), or
- If there is no spreader bar, hang the main drag chain or cable at least 6 feet from the vehicle (**Figure 12244 nos. 2 and 3**).
- Secure the towed vehicle with two additional chains or cables.

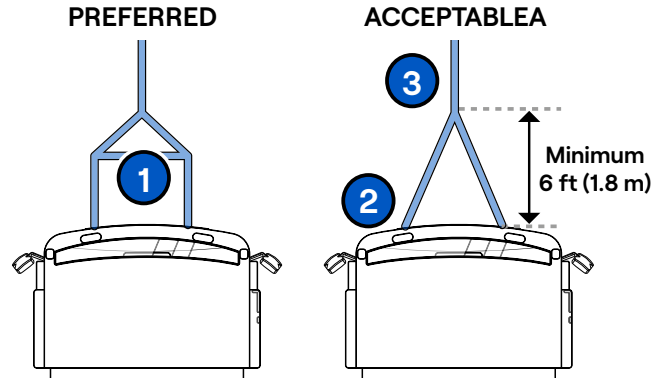

Figure 24 - Recovery options

// TOWING THE VEHICLE

Removing wheel axle half shaft

When performing front lift towing at a speed over 35 mph (50 km/h), a wheel axle half shaft must be removed from each rear wheel to avoid damage to electric motor components.

In this case, be sure to cover the shaft opening to avoid contaminating the oil.

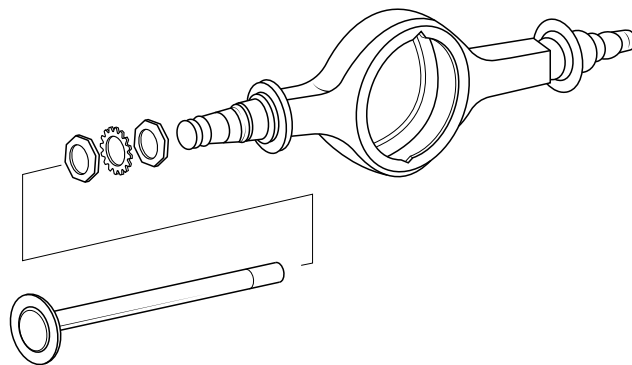

Figure 25 - Wheel axle half shaft

// TOWING THE VEHICLE

Tow hooks

To secure the tow hooks to the chassis:

1. Open the hood and, to secure it in the open position, push both arms of the safety mechanism.
2. Open the accessories compartment (located above the compressed air tanks).

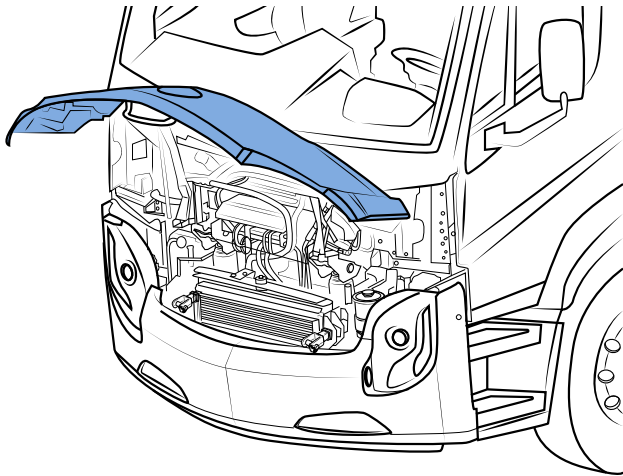

Figure 26 - Hood

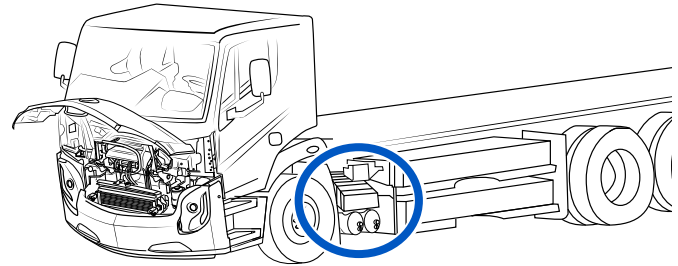

Figure 27 - Location of the accessories compartment

// TOWING THE VEHICLE

3. Remove the tow hooks, the dowel pins and the cotter pins.

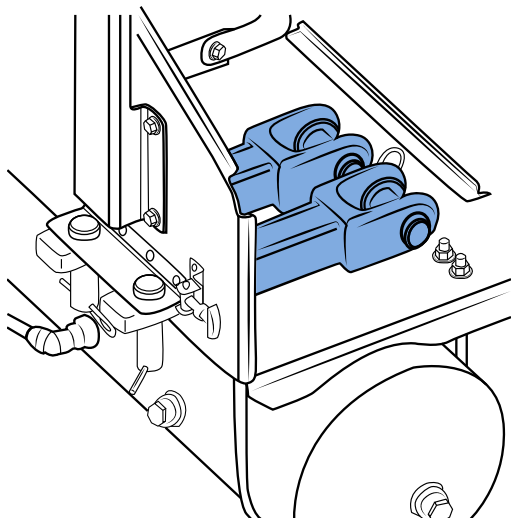

Figure 28 - Tow hooks, dowel pins and cotter pins

4. Insert the two hooks on the front cross member as illustrated in **Figure 129**.

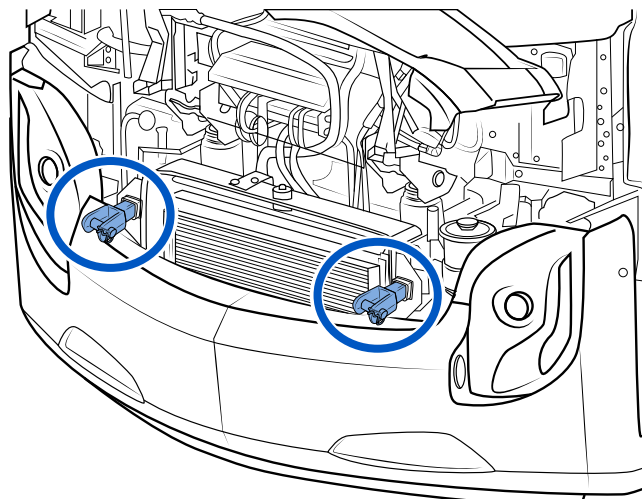

Figure 29 - Tow hooks inserted on the front crossmember

// TOWING THE VEHICLE

5. Secure the tow hooks with dowel pins and cutter pins.
The tow hooks are secured.

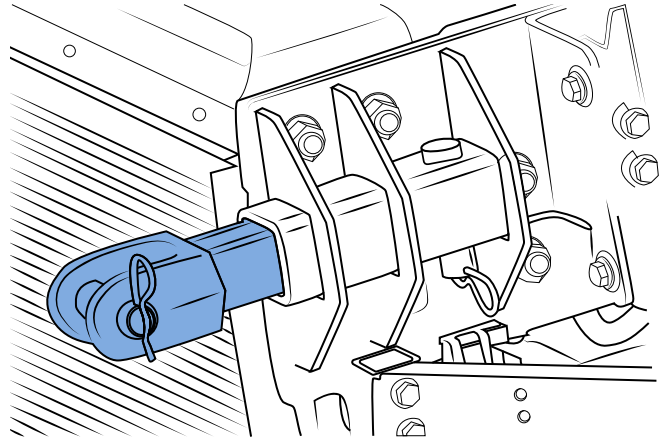

Figure 30 - Tow hook secured with dowel pins and cutter pins

// TOWING THE VEHICLE

Towing in case of electrical breakdown

To tow a vehicle with an electrical breakdown, you must first check if there is any voltage left in the 12 V batteries.

To determine if there is voltage in the batteries, put the key into the starter switch and turn it to the “**ACC**” (Accessory) position (**Figure 31**).

If there is any power left in the 12 V batteries, the indicator lights on the dash will come on. You can now press the “**N**” (Neutral) gear selector (**Figure 32**) and straighten the wheels.

If there is no power left in the 12 V batteries, the indicator lights will not come on. You’ll need to boost the low voltage batteries.

Once the 12 V batteries are charged, you can turn the starter switch to the “**ACC**” (Accessory) position, press the “**N**” (Neutral) gear selector and straighten the wheels.

For the boosting procedure, refer to the *Boosting the low-voltage batteries* section of this manual.

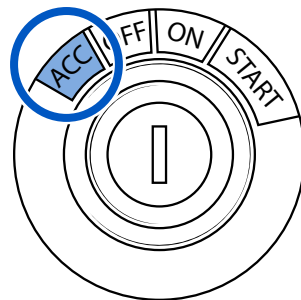

Figure 31 – Accessory “**ACC**” position (Starter switch)

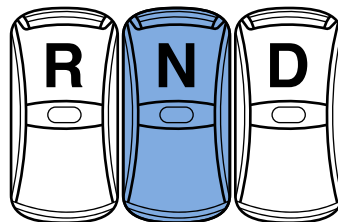

Figure 32 – Neutral “**N**” gear selector



The Lion Electric Company

921 chemin de la Rivière-du-Nord
Saint-Jérôme, Quebec, CANADA J7Y 5G2

1-855-546-6706

Info@thelionelectric.com