

**THIS GUIDE IS INTENDED FOR FIRST RESPONDERS AND CERTIFIED RESCUERS.**

High-voltage batteries are the only energy source for the propulsion of the Lion8 Bucket. Always act as if the high-voltage system is activated. The high-voltage system might be active even when the vehicle emits no sound.

**LION8** Bucket

## Legal Notice

*The information contained in this document is subject to change without notice. This document is intended for first responders and certified rescuers. No part of this document may be reproduced or transmitted in any form without the prior written permission of The Lion Electric Company.*

*The Lion Electric Company cannot be held liable for any errors in this document, or for any damages that may result from the use of this document or the information contained.*

*Intellectual property rights related to this document and the product described are exclusive to The Lion Electric Company and are protected by applicable intellectual property legislation.*

*Copyright © The Lion Electric Company 2024.  
All rights reserved.*

**LION8 Bucket** Emergency Response Guide - 2024/06/07

# CONTENT

<b>VEHICLE IDENTIFICATION</b> .....	<b>5</b>	<b>HOOD</b> .....	<b>14</b>
Identification.....	5	<b>FLUID RESERVOIRS</b> .....	<b>16</b>
<b>EMERGENCY SHUT-OFF</b> .....	<b>6</b>	Under hood reservoirs .....	16
<b>BATTERIES</b> .....	<b>7</b>	Diesel auxiliary heater fuel tank .....	17
Battery types.....	7	<b>TOWING</b> .....	<b>18</b>
High voltage battery characteristics.....	7	Jacking the vehicle .....	18
High-voltage battery location .....	8	Installing tow hooks .....	19
<b>HIGH-VOLTAGE COMPONENTS</b> .....	<b>9</b>	Towing the vehicle.....	22
High-voltage cables .....	9	Towing procedure .....	23
Warning labels .....	9	<b>RECOVERY</b> .....	<b>28</b>
<b>BATTERY DISCONNECT SWITCH</b> .....	<b>11</b>	Front anchoring equipment .....	28
<b>CRASH SENSOR</b> .....	<b>12</b>	<b>12 V/24 V BATTERY RECHARGING</b> .....	<b>30</b>
<b>FIRE AND WATER HAZARD</b> .....	<b>13</b>	Low-voltage batteries recharge.....	30
Fire extinguishment.....	13	Low-voltage batteries emergency boosting.....	30
Submerged vehicle .....	13		

# CONTENT

---

# VEHICLE IDENTIFICATION

---

## Identification

The LION8 Bucket can be identified by the Lion Electric logo located at the center front of the hood.

The logo can also be found on the body of the vehicle and on several chassis components.

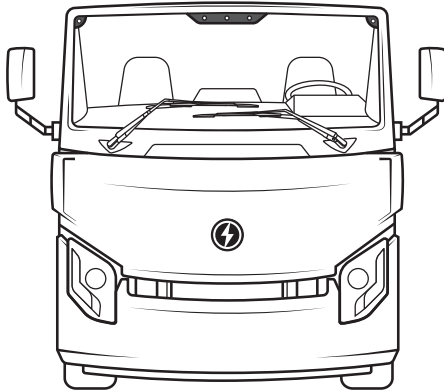

Figure 1 - Front view of the Lion8 Bucket

## Logos

The following logos can be used to identify the LION8 Bucket.



Figure 2 - Lion Electric logo



Figure 3 - Logo

# EMERGENCY SHUT-OFF

---

## Electrical shut-off in case of an emergency:

1. Immobilize the vehicle using the service brake.
2. Apply the parking brake by pulling the yellow knob (**Figure 4**) on the dashboard.
3. Put the vehicle in neutral by pressing the top part of the "N" pushbutton of the drive selector (**Figure 5**).
4. Turn the start switch to the "OFF" position (**Figure 6**).
5. Turn the low voltage battery disconnect switch to the "OFF" position.

The vehicle's low-voltage and high-voltage circuits are turned off.



Figure 4 - Parking brake knob (yellow)

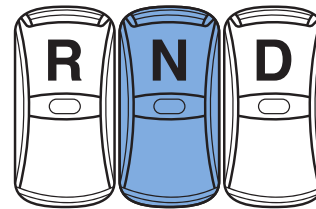

Figure 5 - Drive selector

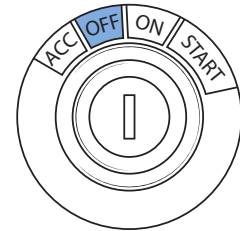

Figure 6 - Start switch

## Battery types

The LION8 Bucket uses two types of batteries that provide low and high voltage.

## High voltage battery characteristics

The LION8 Bucket battery is composed of six 352 V units connected in a series-parallel configuration, providing a nominal voltage of 704 V.

<b>Low voltage automotive-type AGM batteries</b>	<b>High voltage batteries</b>
Three 12 V AGM batteries supply various systems which operate at 12 V (headlights, wipers, etc) or 24 V (Brake booster back-up pump, Multiplexed electrical system, etc).	High-voltage batteries supply power to the electric motor and recharge the 12 V AGM batteries.

**Table 1** - Battery types

# BATTERIES

---

## High-voltage battery location

The Lion8 Bucket is equipped with six high-voltage batteries.

The batteries are located as illustrated in **Figure 7**.

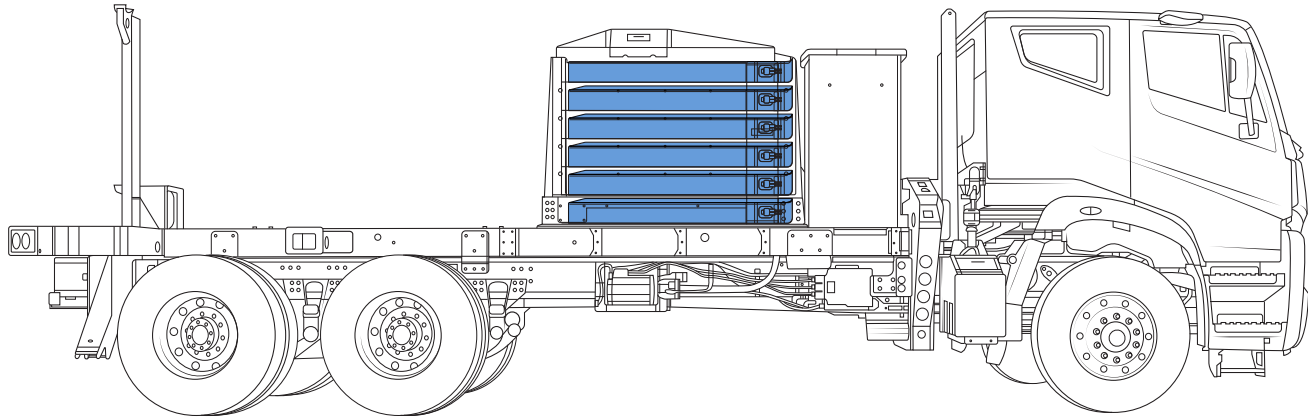

**Figure 7** - High-voltage battery location



# HIGH-VOLTAGE COMPONENTS

## High-voltage cables



High-voltage cables are orange. If an accident occurs, do not touch any high-voltage wiring, connectors, connected components or any metal surface. In case of an emergency, never cut any of the orange high-voltage cables.

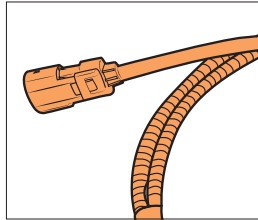
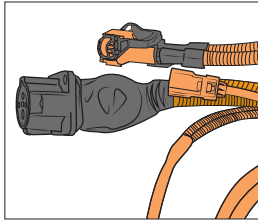
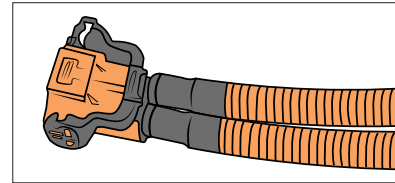

Figure 8 - Examples of orange high-voltage cables

## Warning labels

Vehicles containing high-voltage equipment are equipped with warning labels. Extra attention to the special characteristics of high-voltage technology should be given.



# HIGH-VOLTAGE COMPONENTS

## Warning labels









Label	Meaning	Label	Meaning
	DO NOT turn on the starter switch. Work on high-voltage systems in progress.		CAUTION! High-voltage battery Incorrect handling may cause injury High voltage Risk of explosion Risk of chemical burns and eye injuries
	CAUTION! Hazardous voltage		CAUTION! High voltage The voltage behind this panel is potentially fatal. Access is restricted to qualified personnel.
	CAUTION! High-voltage parts Before working on the vehicle, follow the procedure described in the <i>High-voltage safety disconnect</i> section of this document.		Battery specifications You are in the presence of hazardous voltage.
	HAZARDOUS VOLTAGE! Risk of electrocution Shut off high-voltage equipment.		Danger High voltage Certain components must be disconnected before servicing. Please see the <i>High-voltage safety disconnect</i> section in this manual.

Table 2 – High-voltage equipment labels

# BATTERY DISCONNECT SWITCH

## Battery disconnect switch

The LION8 Bucket is equipped with a low-voltage battery disconnect switch to quickly shut off the low-voltage circuit, which in turn will shut-down the high voltage circuit.

The low-voltage battery disconnect switch is located in the Low Voltage Distribution Unit (LVDU) compartment behind the left front wheel (**Figure 9**). It can be used in case of an emergency or for maintenance purposes.

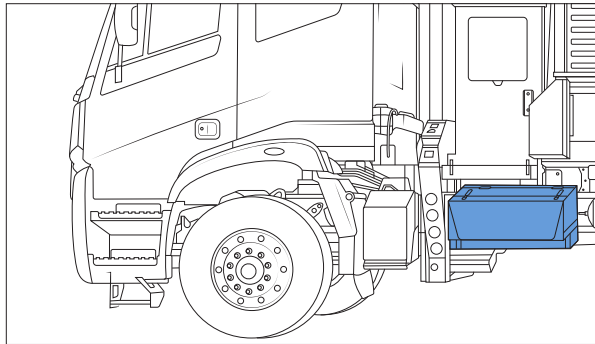

**Figure 9** - Low-voltage distribution unit compartment

## In case of emergency

1. Check to make sure that the vehicle is not charging and that the start switch is turned off.  
Remove the key from the start switch.
2. Turn off the battery disconnect switch to shut off the low-voltage circuit (**Figure 10**).

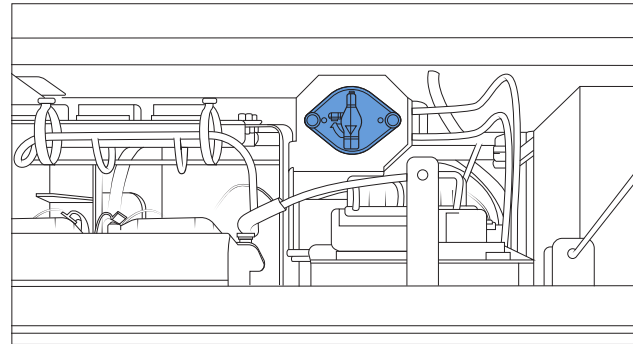

**Figure 10** - Low-voltage battery disconnect switch

# CRASH SENSOR

---

## Crash safety

Deactivation of the high-voltage system and batteries is important when accidents occur for the safety of passengers, first responders and all vehicles involved. For this reason, the battery disconnect safety interlock circuit is linked to the LION8 Bucket's crash sensor. When the sensor detects a collision, it instantly deactivate the high-voltage circuits.

## Crash sensor

If the crash sensor is triggered, it can be reinitialized.

### To reinitialize the crash sensor:

1. Open the hood.
2. Locate the crash sensor and press the button (**Figure 11 and 12**).

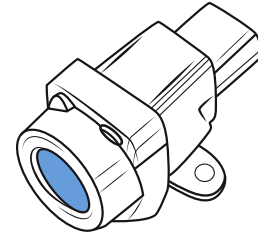

Figure 11 - Crash sensor

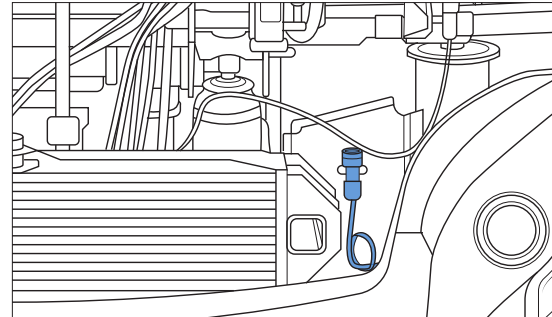

Figure 12 - Location of the crash sensor

# FIRE AND WATER HAZARD

---

## Fire extinguishment

If there is a crack in a battery due to an impact, an inflammable and corrosive electrolyte solution may leak.

If there is a fire in a battery, use a lot of water to cool it down or use CO<sub>2</sub> to extinguish the fire. The battery will not explode.

Depending on availability, other extinguishing agents (fire extinguishing foam or powder) may also be used.

As common in firefighting, complete personal protective equipment (PPE) including self-contained breathing apparatus (SCBA) must be used.

## Submerged vehicle

A Lion8 Bucket that is submerged in water will not present a risk of electrocution since the high-voltage batteries are electrically isolated from the vehicle structure.

Treat a partially or fully submerged Lion8 truck as any other vehicle and use the appropriate personal protective equipment (PPE).

Once the vehicle is removed from water, disable the high voltage circuit by shutting down the low voltage circuit with the battery disconnect switch (**see page 13**).

# HOOD

---

## Under hood components

The LION8 Bucket low-voltage electrical components can be accessed by opening the hood.

### To open the hood:

1. Stand in front of the vehicle and locate the release latches (**Figure 13**) on each side of the front of the hood.
2. Pull both levers at the same time.

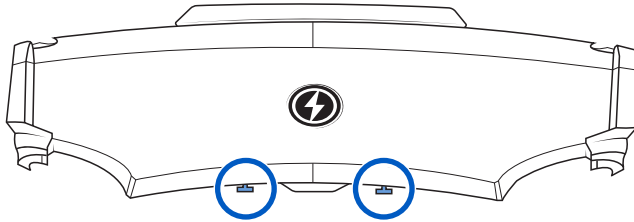

**Figure 13** - Location of hood latches

3. Lift the hood; there is a handle located in the center, at the bottom edge of the hood (**Figure 14**).

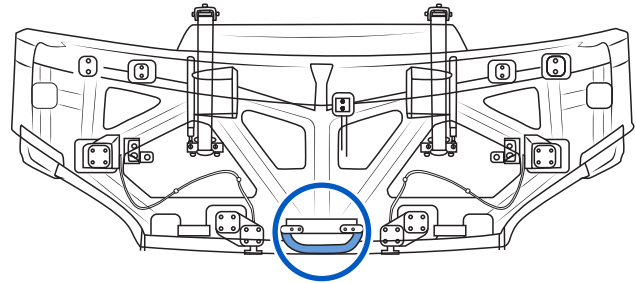

**Figure 14** - Location of handle under the hood

4. Push both arms to lock the hood in the open position (Figure 15).

The hood is open and securely locked in the open position.

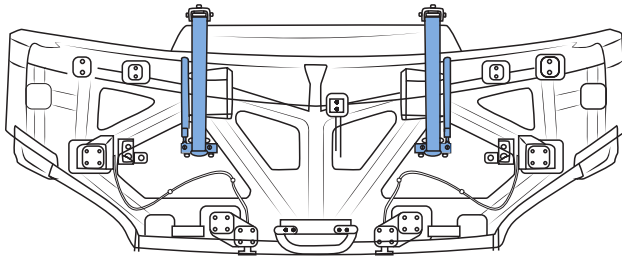

Figure 15 - Hood locking arms

### To close the hood:

1. Grab the center handle, at the edge of the hood (Figure 14), and push the hood gently upwards while pulling on both arms of the safety mechanism (Figure 15) to unlock them.
2. Lower the hood until it latches.

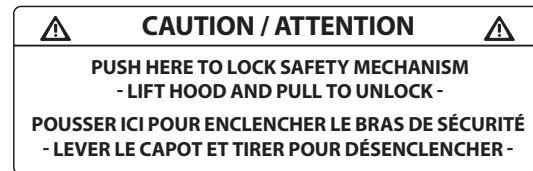

Figure 16 - Safety label under the hood

# FLUID RESERVOIRS

## Under hood reservoirs

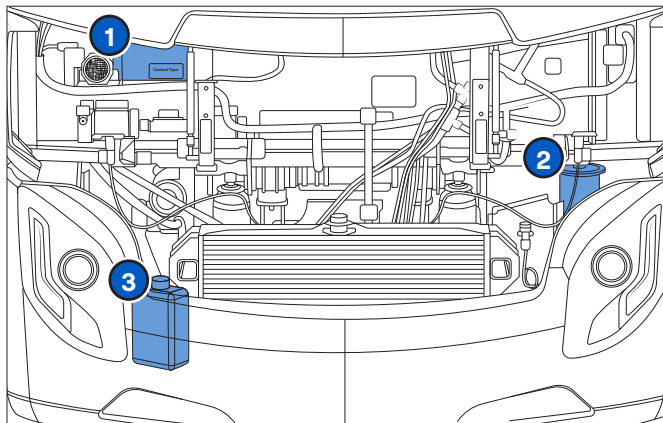

Figure 17 - Location of the fluid reservoirs

N°	Description
1	Cab heater expansion tank (hot liquid)
2	Power steering fluid reservoir (flammable liquid)
3	Windshield washer fluid reservoir

Table 3 - Locations of fluid reservoirs



## FLUID RESERVOIRS

### Diesel auxiliary heater fuel tank

The LION8 Bucket can be equipped with an auxiliary fuel heater. Its reservoir holds 10.57 gallons (40 liters) of diesel fuel and is located behind the right front wheel.

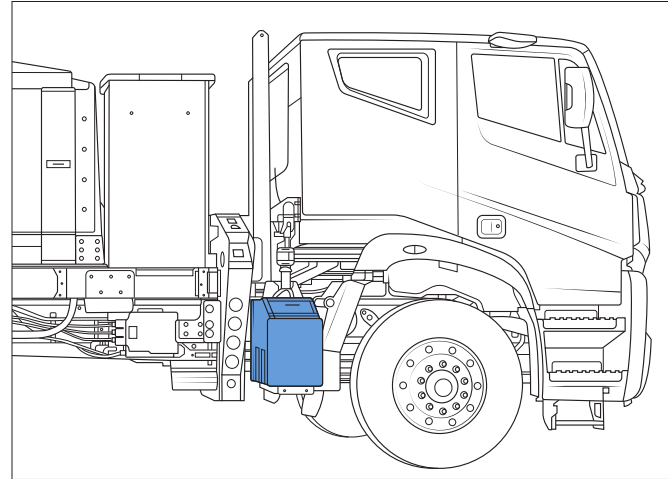

Figure 18 – Location of auxiliary fuel heater

# TOWING

---

## Jacking the vehicle

Proper jacking procedures and basic safety measures must be observed to ensure the safety of personnel while working under the truck. Always check the serviceability of any lifting equipment prior to use.

Ensure that the lifting equipment is of sufficient strength to handle the vehicle, and that the surface provides the necessary strength to support the weight of the vehicle concentrated on the footprint of the jack. Never move under a truck supported only by a hydraulic jack.

1. Park the truck on a flat, level surface of sufficient strength to support the jack.
2. Chock the wheels in both directions.
3. Use only certified jacks and stands of sufficient capacity to support the vehicle. Following the jack manufacturer's recommendations, place the jack securely under the axle at the spring or suspension beam, nearest the tire/wheel to be repaired. Jack the truck only to the height necessary to service.
4. Support the truck with blocks or jack stands under the frame rails.

## Installing tow hooks

To secure the tow hooks to the chassis:

1. Open the hood and, to secure it in the open position, push both arms of the safety mechanism.
2. Open the accessories compartment located just behind the left front wheel.

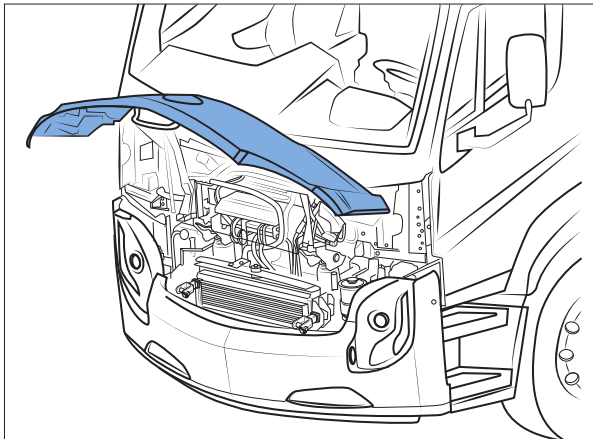

Figure 19 - Hood



Figure 20 - Accessories compartment

# TOWING

---

3. Remove the tow hooks, the dowel pins and their spring pins.



Figure 21 - Tow hooks, dowel pins and spring pins

4. Insert the two hooks in the front receivers as illustrated in Figure 22.

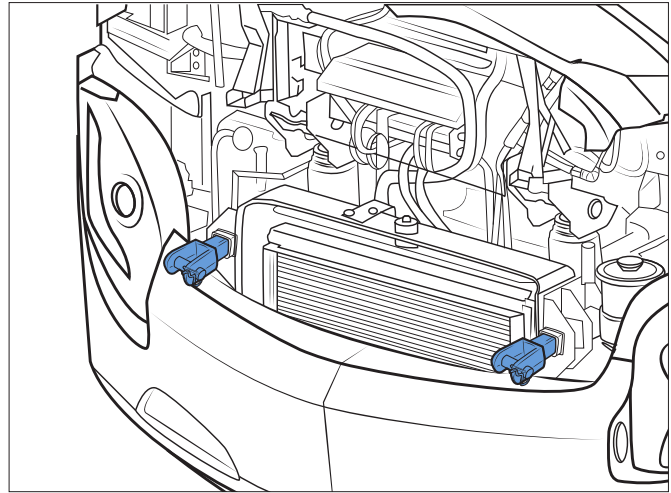
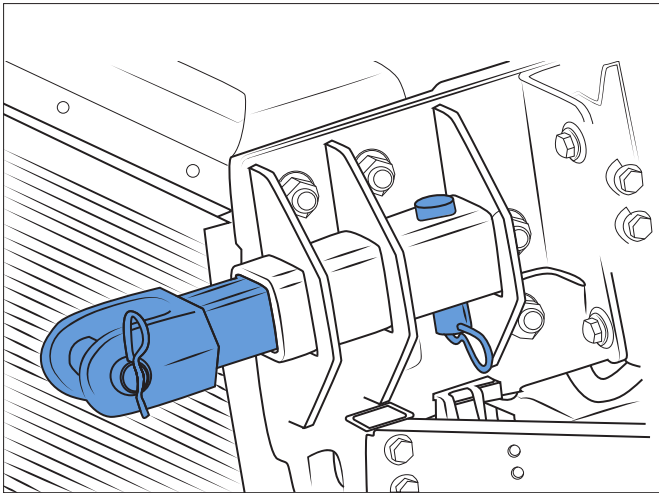

Figure 22 - Tow hooks, inserted in the front receivers

5. Secure the tow hooks with the dowel pins and spring pins. The tow hooks are now ready for use.



**Figure 23** - Tow hook secured with dowel pins and spring pins

# TOWING

---

## Towing the vehicle

### Platform towing

The LION8 Bucket can be towed on a platform. However, **the overall height of the truck on the platform must be within the local restrictions for vertical clearance.**



**Do not tow by lifting the rear end of the vehicle. The vehicle's front axle is not capable of supporting the weight.**

### Unrestricted towing

The LION8 Bucket can be towed any distance by lifting the front axle while leaving the rear wheels in contact with the ground. To do this, **you must remove all four half-shafts from the rear wheels.** Please refer to the following pages to apply the proper towing procedure including removing and reinstalling the half shafts.

Removing the half-shafts prevents damaging the internal components of the rear axles by improper lubrication. It also prevents the drive motor from rotating, which could cause major damage to high voltage components.



**Removing only the main driveshaft (from motor to first axle) for towing is prohibited. This could result in major damage to internal components of the axles.**

## Limited speed emergency towing

In case of an emergency where it is not practical or too dangerous to remove all rear axles half-shafts, it is possible to tow the vehicle at very low speed on a short distance without removing them. However, some parameters must be respected:

- Low voltage battery disconnect switch set to “**OFF**” (see **Figure 10**).
- Maximum towing speed: **20 km/h (12 mph)**.
- Maximum distance: **10 km (6 miles)**.
- Parking brake must be released manually by “caging” all four brake actuators.
- Optional: an external compressed air supply can be provided by the towing vehicle.

When the vehicle is moved to a location where work can be conducted safely, **all rear axles half-shafts must be removed** according to the regular towing procedure.

## Towing procedure

1. Put the vehicle in neutral by pressing the “**N**” button of the drive selector and chock the rear wheels.
2. Connect an air line from the tow truck’s compressed air system to charge the primary air system of the disabled vehicle (minimum 80 psi).
3. Position tow truck’s crossbar and lift adapters beneath the front axle, ensuring the lift adapters are position directly beneath the suspension between the U-bolts.
4. Lift the tow truck’s crossbar until the front axle is seated on the lift adapters and secure the crossbar to the front axle.

# TOWING

---

## Half-Shaft Dismounting

5. Place a drip pan under the center of the wheel hub.
6. Remove the 8 nuts securing the flange to the hub.
7. Remove the half shaft by sliding it out from the center of the hub.

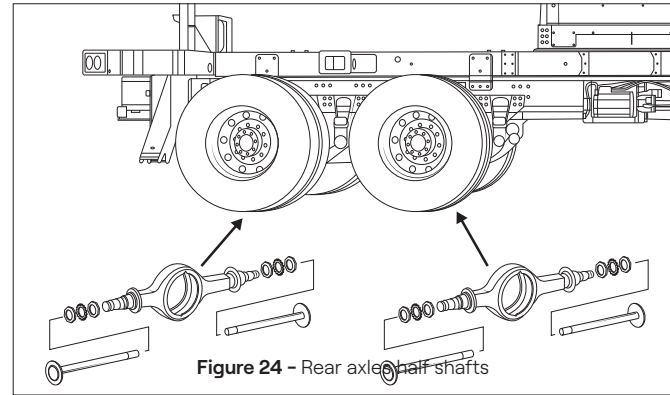



8. Install a suitable hub cover over the opening (**Figure 24**) and reinstall fasteners to seal it.
9. Repeat steps 5 to 8 for the other rear wheels.
10. Continue towing preparation with Manual parking brake release procedure.

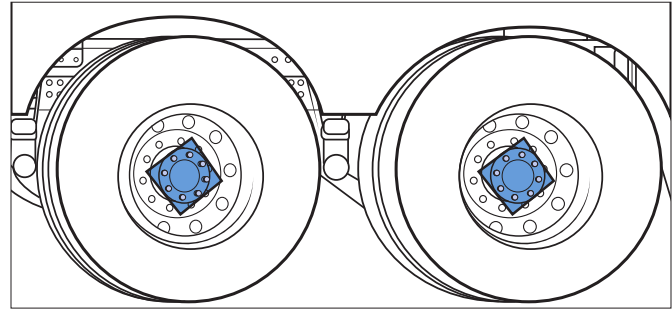

Figure 25 - Hub protection

# TOWING

---

## Manual parking brake release

If all of the air has been evacuated from the pneumatic system or there is an air leak from a brake actuator, you can release the parking brakes by manually compressing (caging) each brake actuator's internal spring. Before manually releasing the parking brakes, chock the wheels to prevent the vehicle from moving.



Always chock the wheels in both directions before starting this procedure: when a parking brake spring is manually caged, the parking brake will no longer operate.

## Manual parking brake release procedure:

1. Release the parking brake from inside the cabin.
2. Remove the dust plug from the brake actuator.
3. Remove the release bolt ("caging bolt") out of its receptacle.

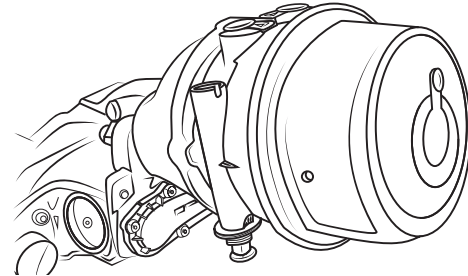
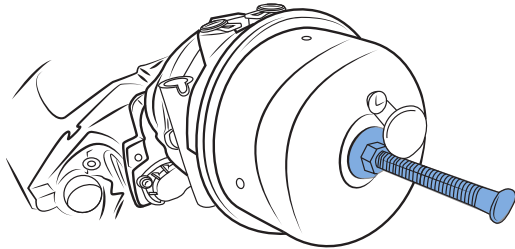

Figure 26 - Brake actuator

# TOWING

4. Insert the release bolt head into the opening at the back of the brake actuator.
5. Turn the release bolt clockwise (1/4 turn) to lock its head in the "T-slot" inside the brake actuator.
6. Tighten the nut until the spring in the actuator is compressed and the parking brake is released.
7. Repeat steps 2 to 6 on the three other brake actuators.
8. Set the vehicle's Low voltage battery disconnect switch to "OFF".
9. Lift the front axle and remove wheel chocks.
10. Retract the recovery boom to position the vehicle into its final towing position.
11. Install towing safety chains.
12. If required, adjust the tow truck's boom height so the towed vehicle's height complies to local regulation.



**Figure 27** - Parking brake release bolt



**Figure 28** - Towing adapters and front axle

# RECOVERY

## Front anchoring equipment

The vehicle's maximum pulling capacity depends on the direction of the pulling force. These are listed in Table 4 and are calculated for two pulling points working simultaneously.

 **WARNING** 

The data in the table above assumes that the constraints are shared equally between the two towing points. Severe damage to the vehicle can occur if the assembly isn't properly secured.

If the vehicle gets stuck or goes off the road, use the towing equipment with extreme caution and observe capacity limits. Damage to axle, suspension or chassis can occur, even if the force at the pulling points is less than maximum capacity.

Direction of the traction exerted	Maximum capacity	
	kg	lb
<b>Straight towards the front</b>	36 287	80,000
<b>Up front in a V</b>	18 144	40,000
<b>Vertical straight</b>	Not allowed	Not allowed
<b>Horizontal straight on the side</b>	4 082	9,000
<b>45 degrees up or down</b>	9 072	20,000
<b>45 degrees straight on the side</b>	5 443	12,000

Table 4 – Tow hooks capacity by direction of pull

# RECOVERY

## Recovery guidelines:

1. Use double chains or cables to distribute the load evenly between both anchoring points (see either recovery option in **Figure 29**).
2. Never run a single chain or cable through both hitches.
3. Use a spreader bar to distribute the load between the two anchoring points (**Figure 29 no. 1**).
4. Without a spreader bar, use two chains or cables at least 6 ft long (**Figure 29 no. 2**) before joining them to the tow truck cable (**Figure 29 no. 3**).
5. Secure the towed vehicle with two additional chains or cables.

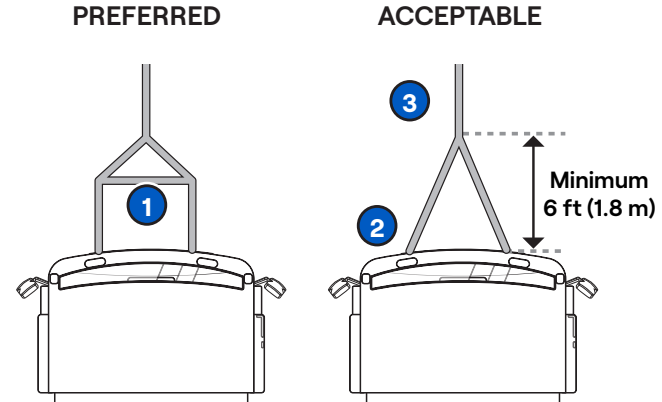

Figure 29 - Recovery options

# 12 V/24 V BATTERY RECHARGING

---

## Low-voltage batteries recharge

To recharge the low-voltage batteries, use an AGM-type battery charger. However, in an emergency, a booster pack or another vehicle can be used to recharge quickly (to “boost”) the batteries. Follow the procedure on the following pages.

## Low-voltage batteries emergency boosting

The Lion8 Bucket high-voltage circuit is linked to the low-voltage circuit batteries (12 V and 24 V). If these batteries are discharged, the high-voltage circuit is disabled.

### Boosting the 12 V circuit single battery:

Hook a 12 V AGM battery charger to the 12 V AGM battery in the LVDU compartment. This is the battery that is closest to the exterior of the LVDU compartment.



**Don't connect the charger negative cable to the vehicle's frame. Connect it to the batteries grounding lug.**

# 12 V/24 V BATTERY RECHARGING

## Boosting the 24 V circuit dual batteries

NOTE: the 24 V circuit is supplied by two 12 V AGM batteries connected in series but their posts are not easily accessible. Follow this procedure to recharge them in series.

1. Using a 24 V charger, connect the charger's negative cable clamp to the **J1 terminal** of the FLEC module (**Figure 30**), which is located in the LVDU compartment.
2. Connect the 24 V charger's positive cable to the **J3 terminal** of the FLEC module (**Figure 30**).
3. Turn the Low Voltage Battery Disconnect Switch to "ON".
4. Activate the battery charger and let it run for a few minutes to recharge the 24 V dual battery circuit.

Once the high voltage circuit can be switched on with the start key, the 24 V charger can be disconnected. The Lion8 onboard DCDC converter will recharge the 12 V and 24 V battery circuit.

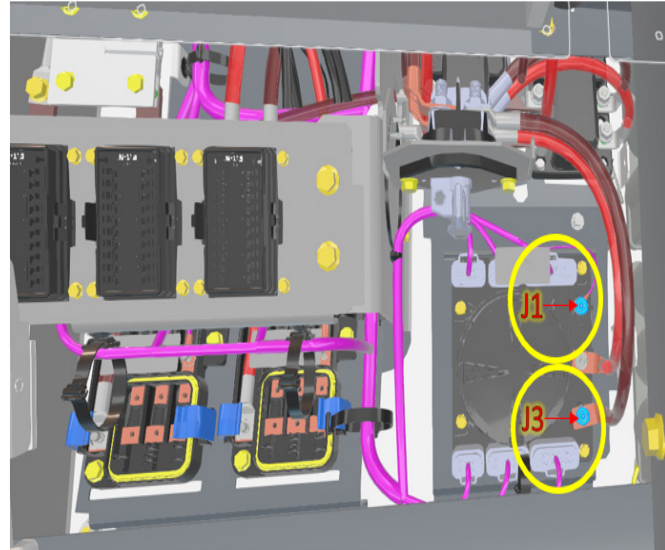
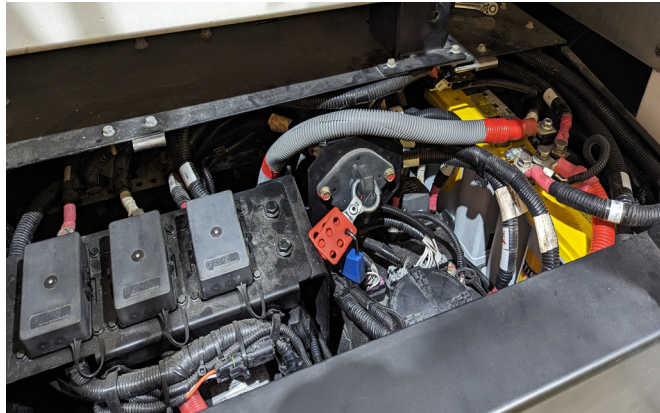

Figure 30 - FLEC module terminals

# 12 V/24 V BATTERY RECHARGING

## Remote Battery posts (optional)

The Lion8 can be equipped with remote battery posts located on the fuseboxes plate in the LVDU compartment (**Figure 31**).



**Figure 31** - 12 V batteries in the LVDU compartment

If equipped, use these posts (**Figure 32, no. 1 and 2**) to recharge the low-voltage circuit batteries.

- The nearest red post is the 24 V positive post (**Figure 32, no. 1**).
- The further back red post is the 12 V positive post (**Figure 32, no. 2**).



**Figure 32** - Remote positive battery posts



## 12 V/24 V BATTERY RECHARGING

Connect the negative cable clamp to the grounding lug of the second battery (**Figure 33**) in the LVDU compartment.



**Figure 33** - Grounding lug







# LION8 Bucket

**The Lion Electric Company**

921 chemin de la Rivière-du-Nord  
Saint-Jérôme, Quebec, CANADA J7Y 5G2  
1-855-546-6706  
[Info@thelionelectric.com](mailto:Info@thelionelectric.com)