

LION[Ⓢ]

EMERGENCY RESPONSE GUIDE

THIS GUIDE IS INTENDED FOR FIRST RESPONDERS AND CERTIFIED RESCUERS.
High-voltage batteries are the only energy source for the propulsion of the LION[Ⓢ].
Always act as if the high-voltage system is activated. The high-voltage system might
be active even when no sound is emitted from the vehicle.

 **LION ELECTRIC**

LEGAL NOTICE

The information contained in this document is subject to change without notice. This document is intended for customers of The Lion Electric Company and for first responders. No part of this document may be reproduced or transmitted in any form without the prior written permission of The Lion Electric Company.

The Lion Electric Company cannot be held liable for any errors in this document, or for any damages that may result from the use of this document or the information contained.

Intellectual property rights related to this document and the product described are exclusive to The Lion Electric Company and are protected by applicable intellectual property legislation.

Copyright © The Lion Electric Company 2020.
All rights reserved.

Legal notice.....	2
CONTENTS.....	3
PRECAUTIONS.....	4
IDENTIFYING THE VEHICLE.....	5
Batteries configuration.....	5
EMERGENCY EXITS.....	6
Rear emergency door.....	6
Emergency roof hatch.....	7
Emergency pushout windows.....	8
Side emergency door.....	10
EMERGENCY EQUIPMENT LOCATIONS.....	11-12
TURNING OFF THE VEHICLE.....	13
Heating system emergency stop.....	14

DISABLING THE HIGH VOLTAGE.....	15
12V battery and safety switch compartment.....	15
What does high voltage (HV) mean?.....	16
Safety precautions.....	16
Warning labels.....	17
Crash safety impact detector.....	18
High-voltage disabling in case of emergency.....	19
FIRE AND WATER IMMERSION.....	20
HOOD ACCESS.....	21
TOWING THE VEHICLE.....	23
Front lift towing.....	23
Using a flatbed.....	25

// PRECAUTIONS



PRECAUTIONS



- **DO NOT** assume that the vehicle is turned off simply because it is quiet.
- Some of the underhood parts get hot and represent burning hazards. Use caution when working on or around these parts.
- To avoid getting electrocuted, do not touch the interior of any battery packs, high-voltage components, or high-voltage fuse box. The high-voltage system may still have a remaining charge even though the system has been turned off.
- If the vehicle is in the water, do not touch any of the high-voltage components or harnesses to avoid shock from the electrical system.
- If you must walk away from the vehicle, warn and notify the appropriate first responder or a rescue individual of the fact that the vehicle is electrically powered and contains a high-voltage system.

// IDENTIFYING THE VEHICLE

Identification

The **LIONC** can be identified by the Lion Electric logo located at the center front of the hood.

The logo can also be found throughout the cabin and on several chassis components. There may also be **LIONC** decals on the front side.



Figure 1 - ⚡ LION ELECTRIC logo

Batteries configuration

The **LIONC** can be equipped with 3, 4 or 5 batteries. In its fullest battery configuration:

- 2 or 4 batteries are located between the front and the rear axle,
- 1 battery is located behind the rear axle.

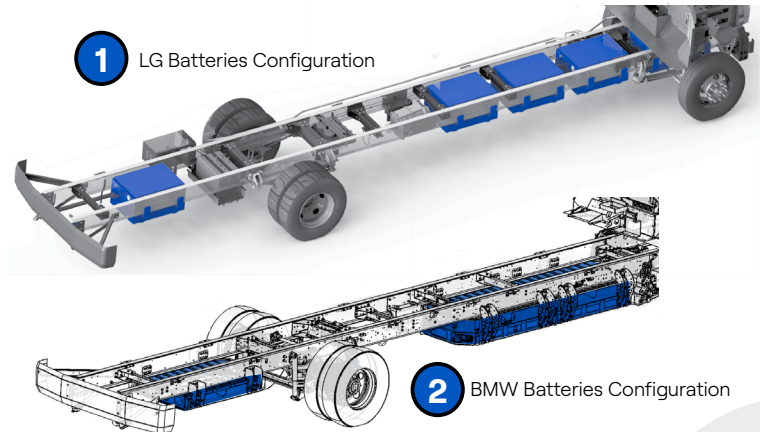

Figure 2 - Batteries configurations

// EMERGENCY EXITS

Emergency exits

The **LIONC** has many emergency exits in addition to the main door that can be used in an emergency.

- Rear emergency door
- Emergency roof hatches
- Emergency pushout windows
- Side emergency door

The bus is equipped with an audible alarm that will go off when an emergency exit is opened.

Rear emergency door

- The emergency exit is located at the back of the vehicle and is clearly indicated as such. The operating method is displayed on the door (**Figure 3**).

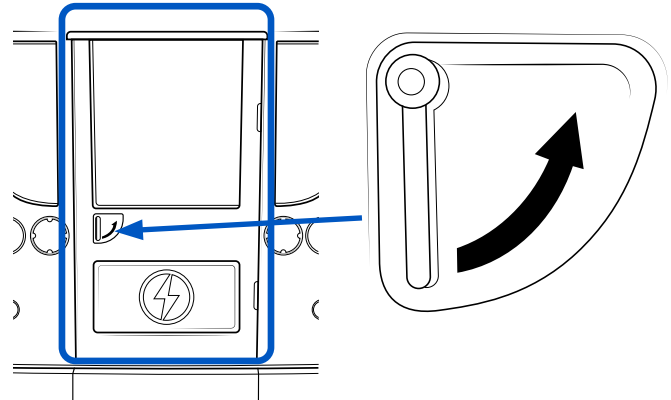

Figure 3 - Exterior view of the **LIONC** emergency door

Emergency roof hatch

Depending on the options and/or regulations, the vehicle may have either no, one or two emergency roof hatch(es) (Figure 5). Some models do not have a roof hatch and will be replaced by a roof vent.

The emergency escape hatch is located on the roof of the vehicle and is clearly indicated as such. The operating method is displayed on the hatch (Figure 4).

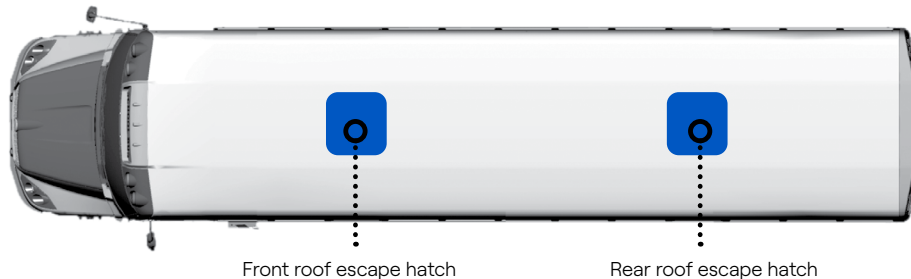

Figure 4 - Emergency roof hatch positions

To open an emergency roof hatch:

1. Turn the red lever to the left to the end stop (Figure 5).
2. Push the hatch outward until it is completely open.

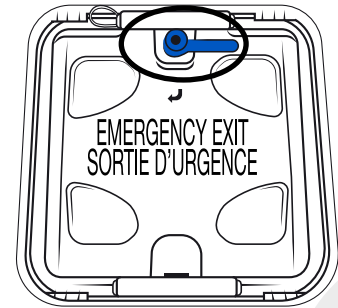

Figure 5 - Emergency roof hatch

// EMERGENCY EXITS

Emergency pushout windows

Standard **LIONC** body will have four pushout windows in the passenger area. You may also find some vehicles that only have two pushout windows in the middle of the body.

Pushout windows are provided as emergency exits in accordance with regulations (**Figure 6 and 7**).

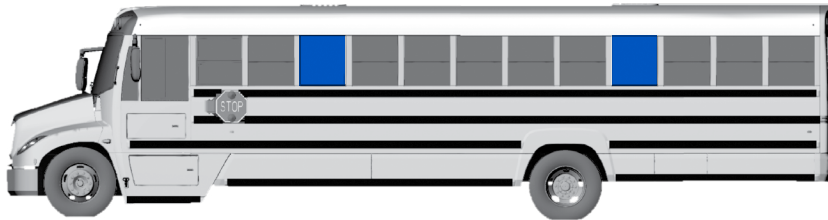

Figure 6 - LIONC emergency pushout windows - left side

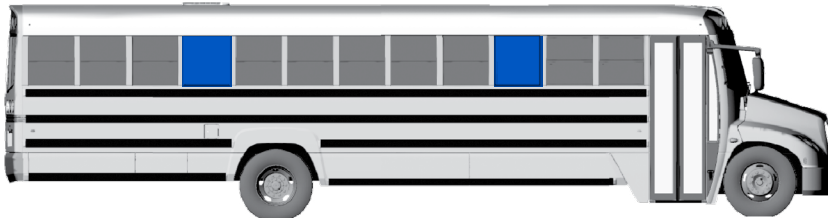

Figure 7 - LIONC emergency pushout windows - right side

// EMERGENCY EXITS

To open the emergency pushout windows from the inside of the vehicle

1. Locate the red handle (Figure 8);
2. Lift the red handle (Figure 9);
3. Push out the window towards the outside (Figure 10).



Figure 8 - Emergency window



Figure 9 - Emergency window

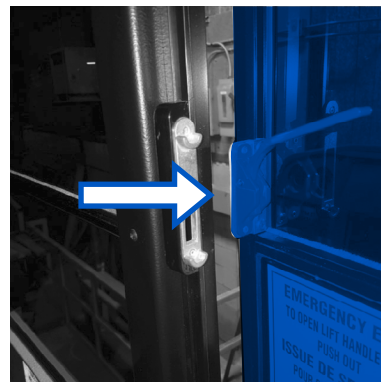

Figure 10 - Emergency window

// EMERGENCY EXITS

Side emergency door.

Some **LIONC** models may have an emergency door. The exit door is then located in the middle of the bus and works the same way as the rear end door. **(Figure 11).**



Figure 11 - **LIONC** side emergency doors

//EMERGENCY EQUIPMENT

Emergency equipment locations

Depending on the **LIONC**'s model, the emergency equipment may differ. Generally, all **LIONC**'s vehicles have first aid kits, fire extinguishers, and triangular roadside hazard reflector kits. The sizes of first aid kits and extinguisher might vary depending on the state regulations. The **LIONC** may also be equipped with a body fluid kit or flare kit. All emergency equipment is generally located in the operator's area.

First aid kit

The first aid kit is mounted on the garbage can holder on the front dash (**Figure 12**).



Figure 12 - First aid kit

//EMERGENCY EQUIPMENT

Fire extinguisher

The fire extinguisher is located just beside the first aid kit. It's mounted in the stepwell area. **(Figure 13).**



Figure 13 - Fire extinguisher

Triangular roadside hazard reflector kit

The triangular roadside hazard reflector kit is mounted behind the operator's seat. **(Figure 14).**



Figure 14 - Triangular hazard reflector kit

// TURNING OFF THE VEHICLE

Turning off the vehicle

1. Press on the brake pedal and put the vehicle in neutral by pressing on the **N** rocker switch located on the dashboard (Figure 15).
2. Apply the parking brake by pulling the lever until it reaches its maximum position (Figure 15).
3. Shut off all electrical loads.
4. Turn off the ignition switch and remove the key (Figure 17).

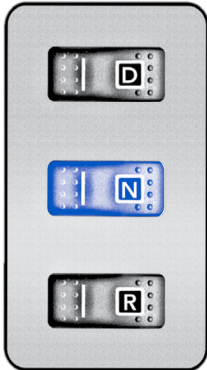

Figure 15 - Gear selector

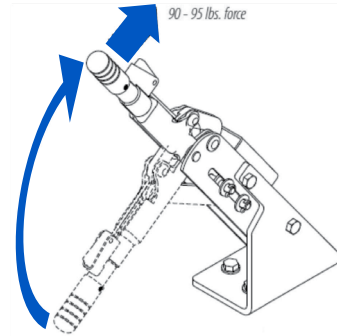

Figure 16 - Parking brake hand lever

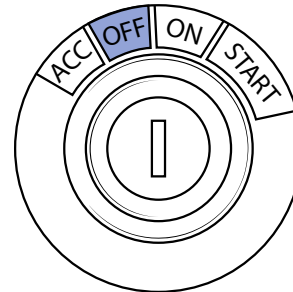

Figure 17 - Ignition switch

// TURNING OFF THE VEHICLE

Heating system emergency stop

The heating system is equipped with an emergency stop pushbutton that deactivate either the fuel heater or the electric defrost.

When you push the emergency switch, the whole heating system will stop. This means the coolant pump, the fuel heater (if applicable) or the electric defroster (if applicable) and all other heating components.

The push button is located at the operator's foot just beside the safety switch (Figure 18).



Figure 18 – Heating system emergency stop pushbutton.

// DISABLING THE HIGH VOLTAGE

Deactivation of the high-voltage system and batteries is important when accidents occur for the safety of the passengers, the first responders and all vehicles involved.

12V battery and safety switch compartment

The compartment is located on the left side of the **LIONC**, near the front. Its primary function is to hold the low-voltage components. The **LIONC** low-voltage components function

on both 12V and 24V. No high voltage is running through the master safety switch. The master safety switch deactivates the high-voltage battery contactors.

The following can be found in the compartment (**Figure 19**):

- Master safety switch (low and high voltage)
- Two low-voltage batteries

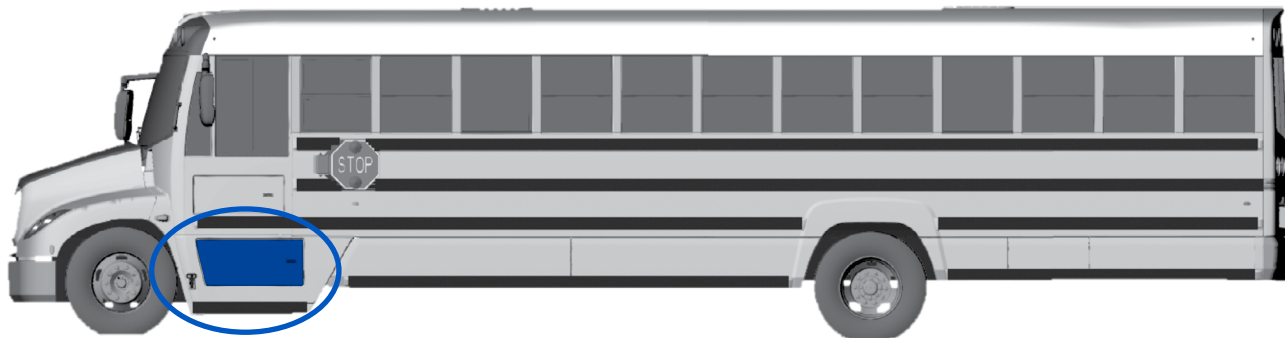

Figure 19 - 12 V battery box and safety switch

// DISABLING THE HIGH VOLTAGE

What does high voltage (HV) mean?

The **LIONC** is equipped with high-voltage systems (HV). We consider high voltage when systems work with voltages above 60 V direct voltage or 25 V alternating. The **LIONC** has some components that will require high levels of electrical power. We can find high-voltage systems that work with direct voltages of up to 400 V and very high peak currents.



DANGER



Always disconnect the cable chargers before working underneath the **LIONC, even if it is not charging.**

Keep your hands and clothing away from cooling fans. Some fans operate even when the **LIONC is powered off.**

Safety precautions

There are basic safety precautions you must take when working with high voltage:

- Avoid the risk of contact with live high-voltage components.
- Only specially qualified personnel may perform work on the high-voltage system.
- In addition to the color coding and warnings given on labels on the components, there are technical safety measures that should be followed.
- The high-voltage system has no user-serviceable parts. **DO NOT** disassemble, remove or replace high-voltage components, cables or connectors.
- High-voltage cables are orange to easily identify them.
- If an accident occurs, do not touch any high-voltage wiring, connectors, components connected to the wiring and any metal surface. In the unlikely event that a fire occurs, immediately contact your local fire emergency responders.

// DISABLING THE HIGH VOLTAGE

Warning labels

When you have to work on high-voltage vehicles, high-voltage components will have warning stickers. Extra attention to the special characteristics of high-voltage technology should be given.







Label	Meaning	Label	Meaning
	DO NOT activate. Work on high-voltage systems in progress.		CAUTION! Hazardous voltage
	CAUTION! High-voltage parts Before working on the vehicle, follow the procedure described in the Disabling the high-voltage section of this document.		CAUTION! High-voltage battery Incorrect handling may cause injury <ul style="list-style-type: none"> • High voltage • Risk of explosion • Risk of chemical burns and eye injuries
	HAZARDOUS VOLTAGE! Risk of electrocution Shut off the high-voltage components.		Battery specifications You are in the presence of hazardous voltage.
	CAUTION! High voltage The voltage behind this panel is potentially fatal. Access is restricted to qualified personnel.		Danger high voltage Certain components must be disconnected before servicing. Please see the Disabling the high voltage section of this document.

Table 1 – High-voltage equipment warning labels

// DISABLING THE HIGH VOLTAGE

Crash safety impact detector

For the safety reasons, the high-voltage safety disconnect switch is linked to the **LIONC** impact sensor. When the sensor reads an impact of at least 8g, it will instantly deactivate the high-voltage circuits.

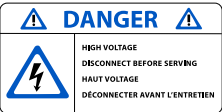

DANGER



ALWAYS assume the high voltage is active. Follow the procedure to disable the high voltage, even if the crash safety detector appears to have been triggered.

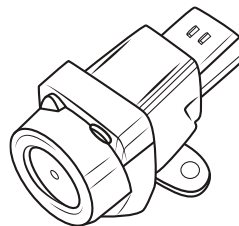

Figure 22- Crash sensor reset button

// DISABLING THE HIGH VOLTAGE

High-voltage disabling in case of emergency

In the event of an emergency, turning either safety switches will disable the high-voltage. **(Figure 20 and Figure 21)**

Double cut the battery cables on both low-voltage batteries located beside the outside safety switch.



This procedure is only valid for first responders in the event of an emergency.

Disabling the high voltage does not entirely remove the risks associated with residual voltage in the vehicle.

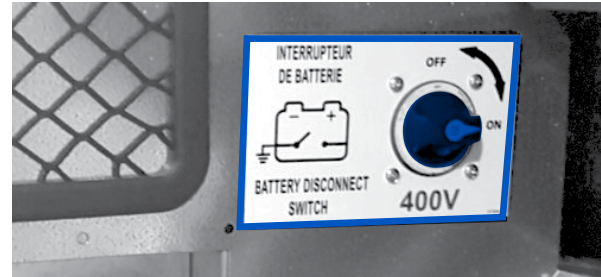

Figure 20 - Driver safety switch

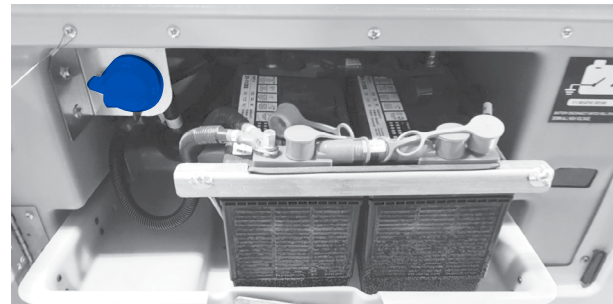

Figure 21 - Outside compartment safety switch

// FIRE AND WATER IMMERSION

Fire extinguishment of high-voltage batteries

If there is a crack in the batteries due to an impact, an inflammable and corrosive electrolyte solution may leak.

If there is a fire in the batteries, use a lot of water to cool down the batteries or CO². The batteries will not explode.

Depending on the availability, other extinguishing agents (fire extinguishing foam, extinguishing powder) may also be used.

As common in firefighting, complete personal protective equipment (PPE) including self-contained breathing apparatus (SCBA) must be used.

If there a fire that is not emerging from the high-voltage batteries, it can be treated using typical vehicle firefighting procedures.

Submerged vehicle

A **LIONC** that is submerged in water will not present the risk of electrocution since the high-voltage batteries are isolated from the vehicle chassis.

Treat a partially or fully submerged **LIONC** as any other vehicle and use the appropriate personal protective equipment (PPE).

Once the vehicle is removed from water, disable the high voltage using the procedure listed in this manual (**See page 20**).



If the vehicle has been immersed in water, turn the battery disconnect switch to the "OFF" position and contact your Lion Service Centre for instructions.

If the vehicle is parked indoors, it must be towed outside and parked away from buildings and other vehicles.

Front hood

Opening the front hood will give you access to the consumable materials of the vehicle.

Opening the hood:

1. Unlatch the right-side hood latch.

Pull the latch handle down and free the elastic latch from the notches of the hood bracket.

Repeat this for the latch on the left side (**Figure 23**).

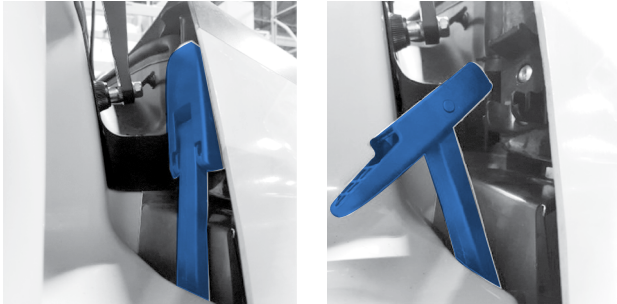

Figure 23–Hood latches

2. At the front of the bus hold the **LION** crest above the radiator grille.

Pull backward lightly, the hood hinge is balanced in such a way that it will require very little effort to lift it.

As the hood rises, control it with your free hand, especially in windy conditions (**Figure 24**).



Figure 24– Hood hinge

// HOOD ACCESS

3. Open the hood completely until it stops slightly beyond its vertical position. **(Figure 25)**

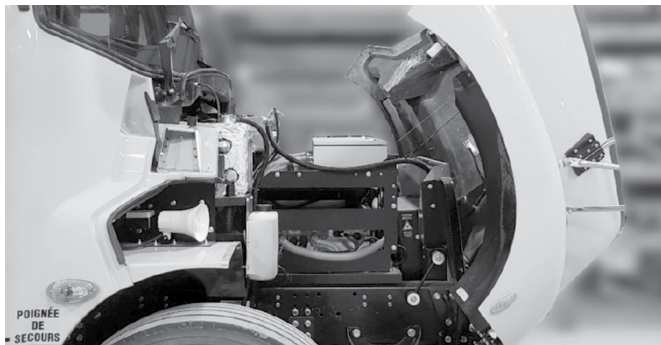

Figure 25- Opened hood

A spring-cushioned cable fixed on the hood will stop it when in its fully open position **(Figure 26)**.

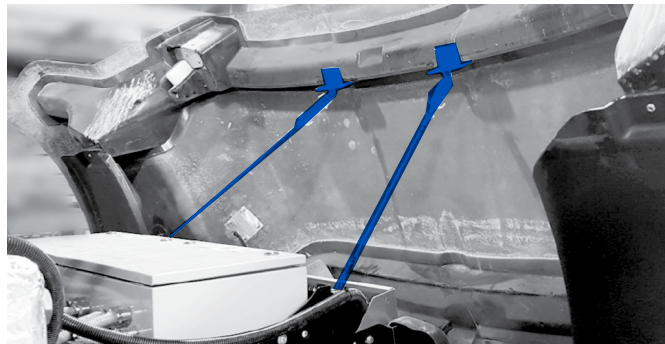

Figure 26- Spring-cushioned cable

// TOWING THE VEHICLE

Towing the Vehicle

This vehicle must be towed by lifting the rear.

Do **NOT** forget to lock the steering wheel.



WARNING



If the vehicle cannot be towed from behind, front towing must be limited to a maximum speed of 25 mph (40 km/h).

In case of emergency, you can tow from the front axle while leaving the rear wheels in contact with the ground. We do not recommend towing the vehicle this way for long distances.

Front lift towing under 25 mph (40 km/h)

If the bus is towed with the rear wheels on the road, the driveshaft must be removed in order to prevent the output shaft from turning, which could damage the electric motor. This is accomplished by removing the rearmost driveshaft.

Removing the driveline

1. Apply the parking brake and chock the wheels while preparing the vehicle for towing.
2. From under the bus locate the rearmost driveshaft in front of the axle housing for removal. Remove the cap screws that secure the yoke straps at the forward universal joint.



Figure 27 - FLIONC front lift towing

// TOWING THE VEHICLE

3. Using a pry bar, carefully apply linear pressure to the shaft allowing the slip joint to provide clearance from the universal joint. Carefully lower the driveshaft allowing it to rest in the driveline guard.
4. Wrap the universal joint on the forward driveline with tape in order to retain bearings.
5. Moving to the rear joint at the axle housing differential, remove the cap screws that secure the yoke straps to the hub. Carefully lower the driveline removing it from the driveline guard.
6. Wrap the universal joint on the end of the removed driveshaft with tape in order to retain bearings.
7. Store driveshaft in rear of the bus in preparation for towing.
8. After tow truck has been hooked to bus, remove wheel chocks.
9. Discard removed cap screws and straps. New cap screws and straps will be required for reinstallation of driveshaft. Torque cap screws to 45-60 ft.-lbs (61.01-81.34 Nm).

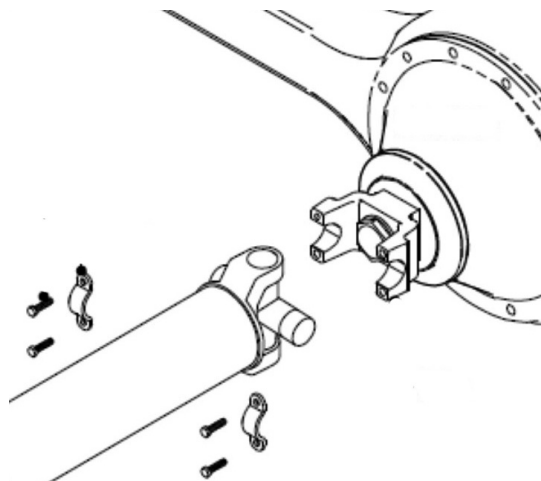

Figure 28 - Friveline removal

// TOWING THE VEHICLE

Using a flatbed

Using a flatbed is the safest and easiest way to tow a **LIONC**. You just drive the vehicle onto the flatbed trailer without removing any parts on the vehicle.



Figure 29- Flatbed towing



WARNING



When towing the vehicle, the transmission output shaft must not be allowed to spin or turn. If the vehicle is towed with the drive wheels still in contact with the road surface, the vehicle driveline must be removed or disconnected. Do not attempt to push or pull start the vehicle.

Make sure the driveshaft is installed correctly after towing. Tighten driveshaft nuts to the appropriate torque settings. Do not invert shafts.



THE LION ELECTRIC COMPANY

921 Rivière-du-Nord Road
Saint-Jérôme, Quebec CANADA J7Y 5G2
1-855-546-6706
Info@thelionelectric.com