

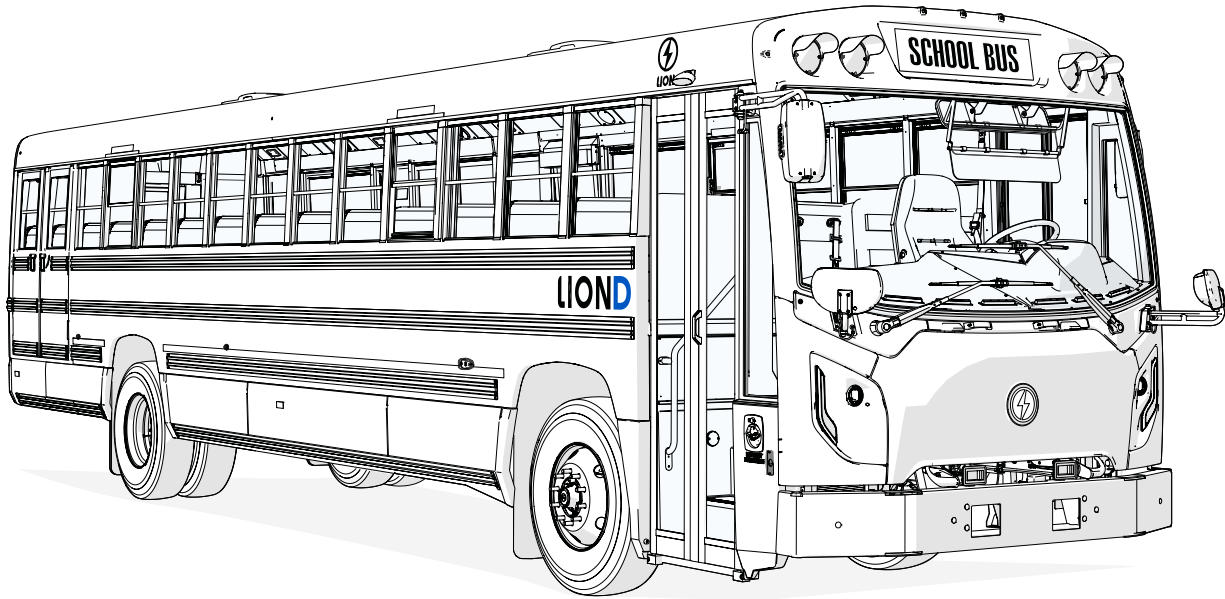

Emergency Response Guide



This guide is intended for first responders and certified rescuers. high-voltage batteries are the only energy source for the propulsion of the LionD. Always act as if the high-voltage system is activated, the high-voltage system might be active even when the vehicle emits no sound.

LIOND

Legal Notice

The information contained in this document is subject to change without notice. This document is intended for first responders and certified rescuers. No part of this document may be reproduced or transmitted in any form without the prior written permission of The Lion Electric Company.

The Lion Electric Company cannot be held liable for any errors in this document, or for any damages that may result from the use of this document or the information contained.

Intellectual property rights related to this document and the product described are exclusive to The Lion Electric Company and are protected by applicable intellectual property legislation.

*Copyright © The Lion Electric Company 2024.
All rights reserved.*

LIOND Emergency Response Guide - 2024/09/26

IDENTIFYING THE VEHICLE	6	EMERGENCY EXITS	14
Identification.....	6	To open the emergency pushout windows.....	15
Battery configuration	6	Emergency equipment locations.....	16
VEHICLE ACCESS	7	EMERGENCY EQUIPMENT	16
To open the front door from the outside	7	First aid kit.....	16
To open the front door from inside.....	8	Fire extinguisher.....	17
Emergency exits.....	9	Triangular roadside hazard reflector kit.....	17
Rear emergency door.....	9	Turning off the vehicle	18
Left-side emergency door	11	TURNING OFF THE VEHICLE	18
Vandal lock protection	11	Heating system emergency stop.....	19
Using the main entry and exit door in an emergency	12		
Emergency roof hatch	13		
Emergency exit windows.....	14		

CONTENT

DISABLING THE HIGH VOLTAGE 20

Low Voltage Battery Compartment	20
What does high voltage (HV) mean?	21
Safety precautions	21
Warning labels (continued)	23
Crash safety impact detector	24
High-voltage disabling in case of emergency	25

FIRE AND WATER IMMERSION 27

Fire extinguishment of high-voltage batteries	27
Submerged vehicle	27

HOOD ACCESS 28

Hood	28
----------------	----

FLUID RESERVOIRS 29

Fluid tank locations	29
--------------------------------	----

RECOVERY AND TOWING 30

Recovery	30
Towing	30

TOWING THE VEHICLE 31

Preparation	31
Preparation	32
Half-Shaft Dismounting	33
Parking brake manual release	34
Finalization	34
Preparing Vehicle for Road Use	35
Parking Brake Release Bolts Removal	35
Axle Shafts Re-installation Procedure	35

 **WARNING** 

- **DO NOT** assume that the vehicle is turned off simply because it is quiet.
- Some of the parts under the hood get hot and present burning hazards. Use caution when working on or around these parts.
- To avoid getting electrocuted, do not touch the interior of any battery packs, high-voltage components, or high-voltage fuse box. The high-voltage system may still have a remaining charge even though the system has been turned off.
- If the vehicle is in the water, do not touch any of the high-voltage components or harnesses to avoid shock from the electrical system.
- Vehicles that have been submerged in water should be handled with a greater caution due to an elevated risk of high voltage battery fire.
- If you must walk away from the vehicle, warn and notify the appropriate first responder or a rescue individual of the fact that the vehicle is electrically powered and contains a high-voltage system.

IDENTIFYING THE VEHICLE

Identification

The LionD can be identified by the Lion Electric logo located at the center front of the hood.

The logo can also be found throughout the cabin and on several chassis components. There may also be LionD decals on the front side.

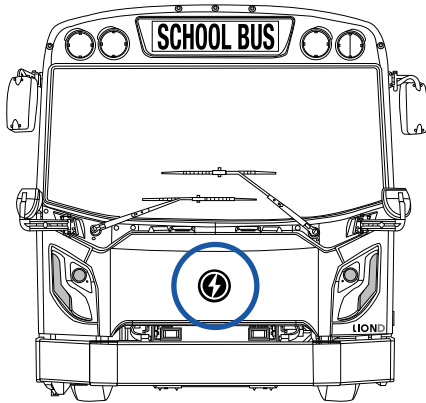

Figure 1 - logo

Battery configuration

The LionD can be equipped up to 5 battery packs. In its fullest battery configuration:

- 2 or 4 batteries are located between the front and the rear axle,
- 1 battery is located behind the rear axle.

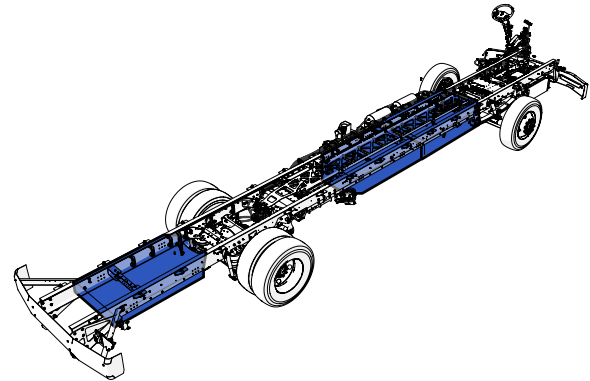

Figure 2 - Potential locations for batteries

To open the front door from the outside:

When power is present:

1. Insert key and turn clockwise to unlock, and automatically open the door.
2. Turn the key counterclockwise to lock and automatically close the door.

Emergency Door Manual Operation:

1. If unlocked the Emergency Door Release Handle can be unfolded turned clockwise a 1/4 turn to allow manual operation of the door.
2. Pull on the door handle to manually open the door.

To reset the emergency door, the Emergency Door Release Handle must be turned counterclockwise to its original position, and the emergency door release lever above the door on the interior of the vehicle must be reset by switching it to the right.

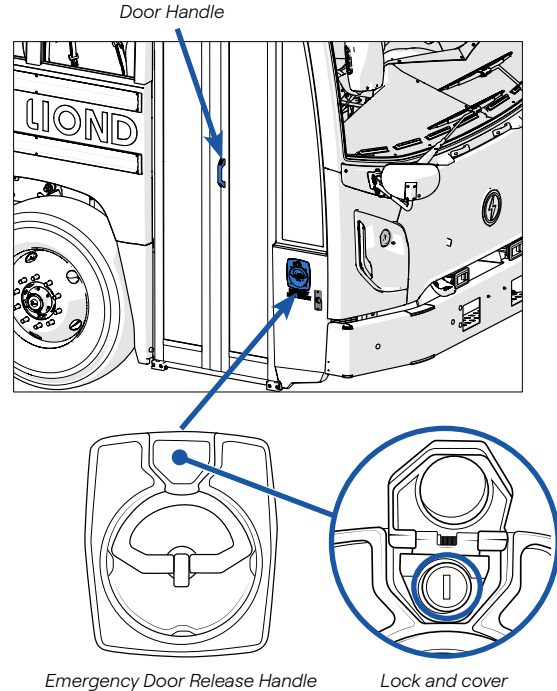

Figure 3 - Door handle and lock location

VEHICLE ACCESS

To open the front door from inside:

- Press the "DOOR OPEN" pushbutton located on the steering wheel (Figure 4 no. 1).

To close the front door from inside:

- Press the "DOOR CLOSE" pushbutton (Figure 4 no. 2).

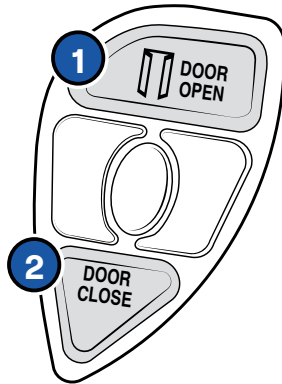

Figure 4 - Front door commands

To open the front door of the vehicle using the emergency door release lever:

1. Slide the red lever above the front door to the left (front of the bus) to unlock the door (Figure 5).
2. Push the FRONT door panel outward. The rear door panel will follow.

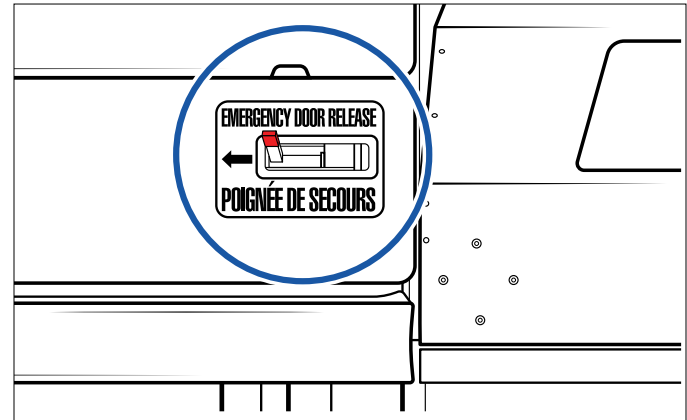

Figure 5 - Emergency release handle

Emergency exits

The LionD has several emergency exits in addition to the main door that can be used in an emergency.

- One rear emergency door located at the back of the vehicle and clearly indicated as such. The opening method is displayed on the door.
- Two emergency escape hatches located on the roof of the vehicle and clearly indicated as such. The opening method is displayed on the hatches.
- One side emergency door located on the left of the vehicle. The opening method is displayed on the door.
- Four emergency opening windows, two per side. The opening method is displayed on the windows.

The bus is equipped with an audible alarm that will go off when an emergency exit is opened. The alarm is triggered only when the starter switch is in the “**ON**” position.

Rear emergency door

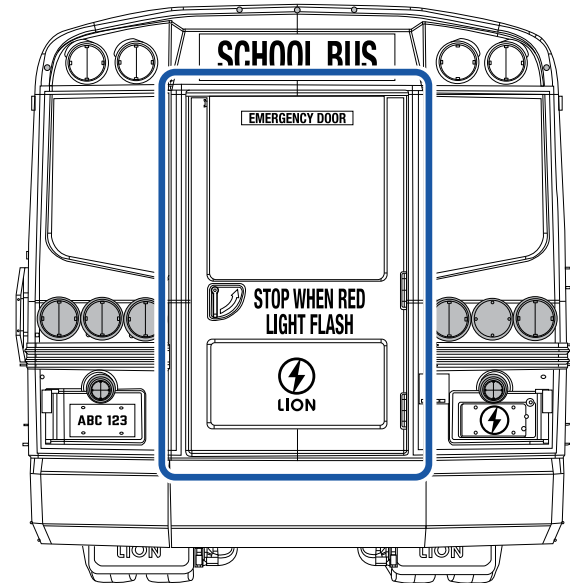

Figure 6 – Exterior view of the **LIOND** emergency door

VEHICLE ACCESS

To open the rear or side emergency doors from inside the vehicle:

- Pull the handle up and push the door outward (**Figure 7**).

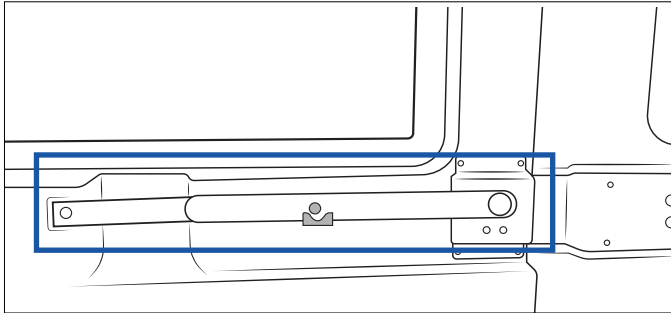

Figure 7 - Rear or side emergency door handle (inside view)

To open the rear or side emergency doors from outside the vehicle:

- Lift the handle upward and swing the door open (**Figure 8**).

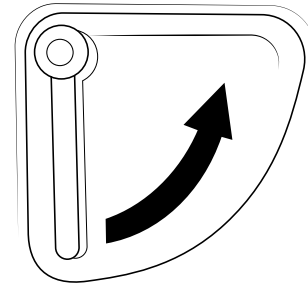

Figure 8 - Rear or side emergency door handle (outside view)

Left-side emergency door

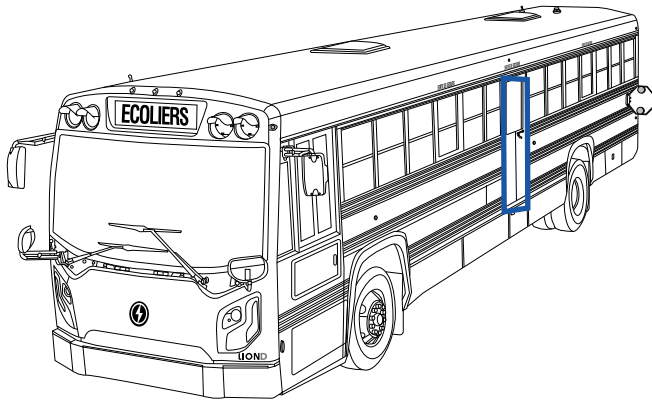

Figure 9 - Left-side emergency door

Vandal lock protection

The Vandal lock is a special device that locks the inner door handle of the rear and the side emergency doors. When the locking cylinders are installed on the inner emergency door handles, the vehicle cannot be started.

To start the vehicle, both locking cylinders must be removed from the doors and placed in their receptacles in the vehicle's console (to the left of the operator's seat). The safety circuit is then completed and the vehicle can be started.

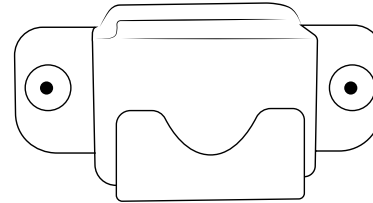

Figure 10 - Emergency door vandal lock

VEHICLE ACCESS

The vandal lock is located in the center of the red lever that locks both emergency doors (**Figure 11**).

To lock the emergency doors:

1. Once the emergency door is closed, remove the locking cylinder from the receptacle to the left of the driver's seat.
2. Insert the locking cylinder in the vandal lock, blocking the red lever of the emergency door.
3. Repeat for the other emergency door.

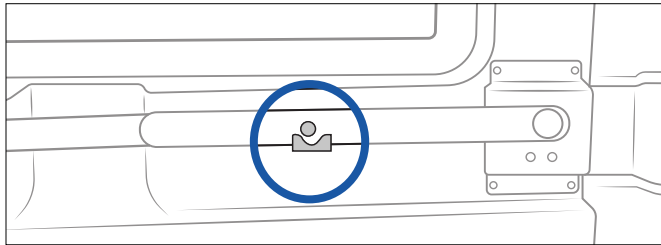

Figure 11 - Location of the vandal lock on the emergency door

Using the main entry/ exit door in an emergency

In an emergency, it may be necessary to use the red lever above the main door to open it.

To open the door with the emergency door release lever:

1. Slide the red lever above the door to the left to unlock the door (**Figure 12**).
2. Push the FRONT door panel outward. The rear panel will follow.

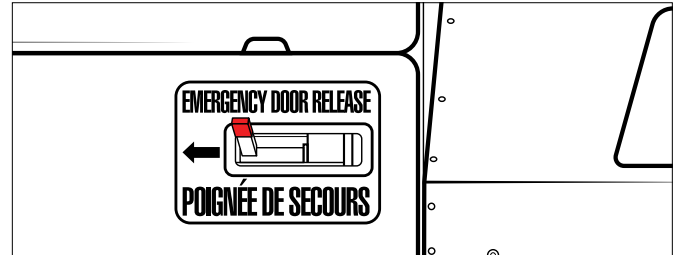

Figure 12 - Emergency release handle

Emergency roof hatch

The vehicle is equipped with two emergency roof hatches. An alarm sound is emitted when an emergency hatch is open (if the key is « ON »). Opening instructions are clearly marked on the hatch panels.

To open an emergency roof hatch:

1. Turn the red lever clockwise (**Figure 13**).
2. Push the hatch outward until it is completely open.

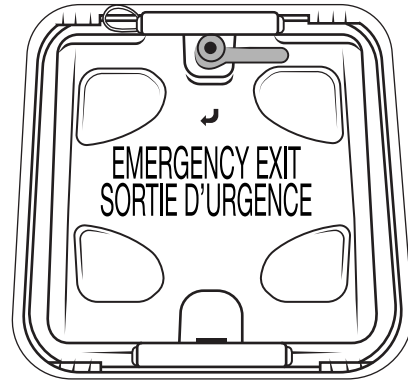

Figure 13 - Emergency roof hatch

EMERGENCY EXITS

Emergency exit windows

The LionD has four windows that can be opened from the inside and used as emergency exits.

A decal is affixed near the unlocking handle of each emergency exit window to indicate its operating instructions.

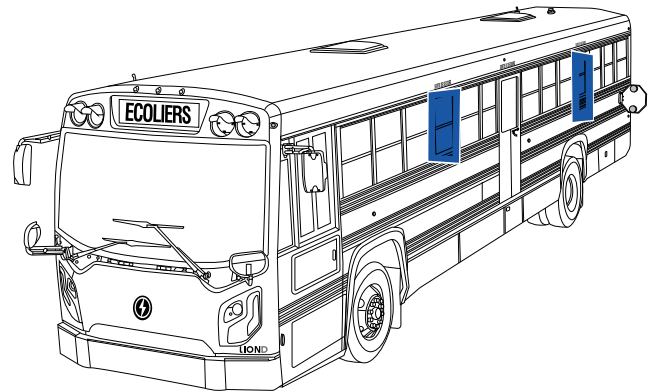
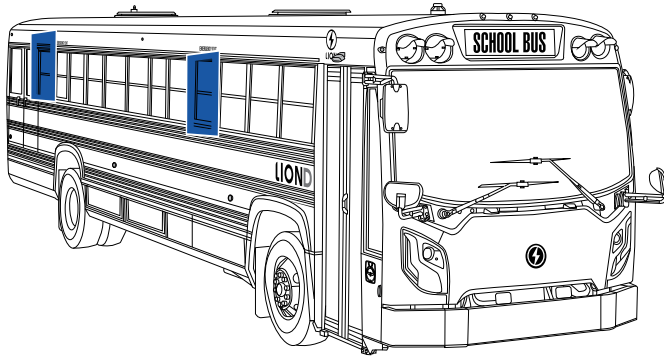

Figure 14 – Location of the four emergency pushout windows (two per side)

To open the emergency pushout windows from the inside of the vehicle

1. Locate the red handle (**Figure 15**);
2. Lift the red handle (**Figure 16**);
3. Push out the window towards the outside (**Figure 17**).



Figure 15 - Emergency window



Figure 16 - Emergency window

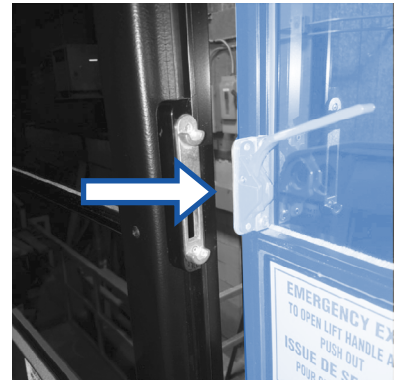

Figure 17 - Emergency window

EMERGENCY EQUIPMENT

Emergency equipment locations

Depending on the LionD's model, the emergency equipment may differ. All LionD's vehicles have first aid kits, fire extinguishers, and triangular roadside hazard reflector kits. The sizes of first aid kits and extinguisher might vary depending on the state regulations. The LionD may also be equipped with a body fluid kit or flare kit. All emergency equipment is generally located in the operator's area.

First aid kit

The first aid kit is mounted in the stepwell area, near the front door (**Figure 18**).



Figure 18 - First aid kit

Fire extinguisher

The fire extinguisher is located just beside the first aid kit. It's mounted in the stepwell area. **(Figure 19).**



Figure 19 - Fire extinguisher

Triangular roadside hazard reflector kit

The triangular roadside hazard reflector kit is mounted behind the operator's seat. **(Figure 20).**

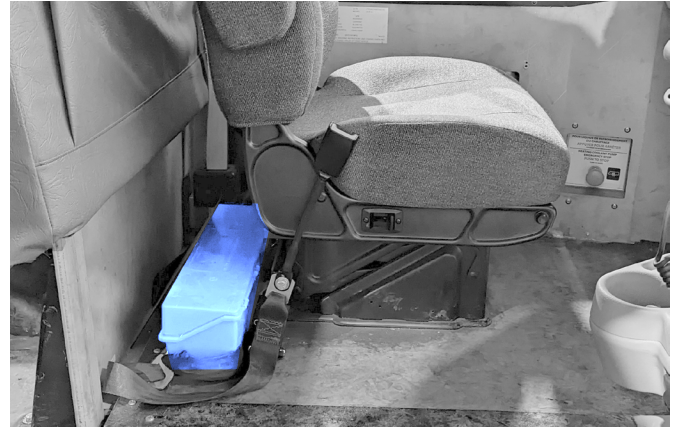

Figure 20 - Triangular hazard reflector kit

TURNING OFF THE VEHICLE

Turning off the vehicle

1. Press on the brake pedal and put the vehicle in neutral by pressing on the **N** rocker switch located on the dashboard (**Figure 21**).
2. Apply the parking brake by pulling the yellow knob on the dashboard (**Figure 22**).
3. Turn off the ignition switch and remove the key (**Figure 23**).



Figure 21 - Gear selector

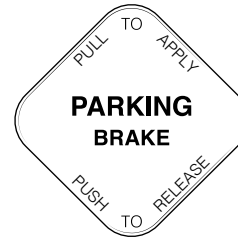

Figure 22 - Parking brake air supply control

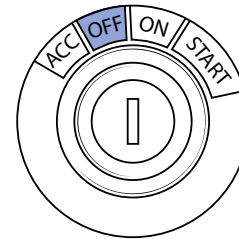

Figure 23 - Ignition switch

Heating system emergency stop

The heating system is equipped with an emergency stop pushbutton that deactivates the heating circuit pump.

When you push the emergency switch, the whole heating system will stop. This means the coolant pump, the fuel heater (if applicable) or the electric defroster (if applicable) and all other heating components.

The push button is located on the left of the operator's foot, near the floor (**Figure 23**). The emergency switch can be reset by twisting the knob counterclockwise.

Deactivation of the high-voltage system and batteries is important when accidents occur for the safety of the passengers, the first responders and all vehicles involved.

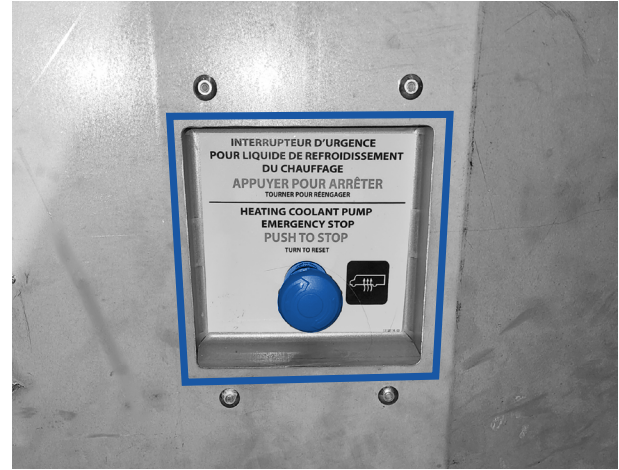

Figure 23 - Heating system emergency stop pushbutton.

DISABLING THE HIGH VOLTAGE

Low Voltage Battery Compartment

The compartment is located on the left side of the LionD, near the front. Its primary function is to hold the 12V batteries and the Low Voltage Disconnect Switch. The LionD low-voltage components function on both 12V and 24V. No high voltage is running through the battery disconnect switch. The low voltage disconnect switch deactivates the low voltage circuit, disabling the activation of High Voltage.



Figure 24 - 12 V battery compartment

The following can be found in the compartment (Figure 24):

- Battery disconnect switch (low voltage only) (Figure 25 no. 1)
- Two 12V batteries (Figure 25 no. 2)

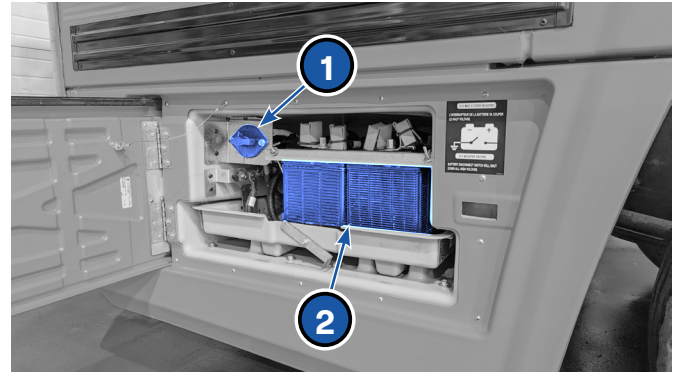

Figure 25 - 12 V battery box and safety switch

What does high voltage (HV) mean?

The LionD is equipped with high-voltage systems (HV). We consider high voltage when systems work with voltages above 60V DC or 25V AC. The LionD has some components that will require high levels of electrical power. We can find high-voltage systems that work at up to 400V DC and very high peak currents.



Always disconnect the charging cable before working underneath the LionD, even if it is not charging.

Keep your hands and clothing away from cooling fans. Some fans operate even when the LionD is powered off.

Safety precautions

There are basic safety precautions you must take when working with high voltage:

- Avoid the risk of contact with live high-voltage components.
- Only specially qualified personnel may perform work on the high-voltage system.
- In addition to the color coding and warnings given on labels on the components, there are technical safety measures that should be followed.
- The high-voltage system has no user-serviceable parts.
- **DO NOT** disassemble, remove or replace high-voltage components, cables or connectors.
- High-voltage cables are orange to easily identify them.
- If an accident occurs, do not touch any high-voltage wiring, connectors, components connected to the wiring and any metal surface. In the unlikely event that a fire occurs, immediately contact your local fire emergency responders.

DISABLING THE HIGH VOLTAGE

When you have to work on high-voltage vehicles, high-voltage components will have warning stickers. Extra attention to the special characteristics of high-voltage technology should be given.





Label	Meaning
	<p>DO NOT turn on the start switch. Work on high-voltage systems in progress.</p>
	<p>CAUTION! Hazardous voltage</p>
	<p>CAUTION! High-voltage parts Before working on the vehicle, follow the procedure in the <i>Disabling the high-voltage battery</i> section of this document.</p>
	<p>HAZARDOUS VOLTAGE! Risk of electrocution. Shut off high-voltage equipment.</p>
	<p>CAUTION! High-voltage battery Incorrect handling may cause injury. High voltage, risk of explosion, risk of chemical burns and eye injuries</p>

Table 1 - Warning labels

Warning labels (continued)



Label	Meaning
	<p>CAUTION! High voltage</p> <p>The voltage behind this panel is potentially fatal. Access is restricted to qualified personnel.</p>
	<p>Battery specifications</p>
	<p>Danger! High voltage</p> <p>Disconnect certain components before servicing. Please see the <i>Disabling the high-voltage battery</i> section in this manual.</p>

Table 1 - Warning labels

DISABLING THE HIGH VOLTAGE

Crash safety impact detector

For safety reasons, the high-voltage safety disconnect switch is linked to the LionD' crash sensor. When the sensor detects an impact of 8g or more, it will instantly deactivate the high-voltage circuits.



ALWAYS assume the high voltage is active. Follow the procedure to disable the high voltage, even if the crash sensor detector appears to have been triggered.

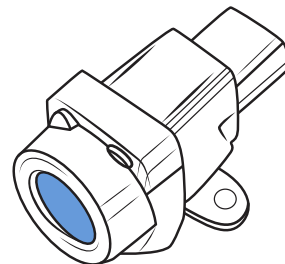

Figure 26 - Crash sensor reset button

High-voltage disabling in case of emergency

In the event of an emergency, turning the low voltage disconnect switch will disable the high-voltage. (Figure 28)



This procedure is only valid for first responders in the event of an emergency.

Disabling the high voltage does not entirely remove the risks associated with residual voltage in the vehicle.

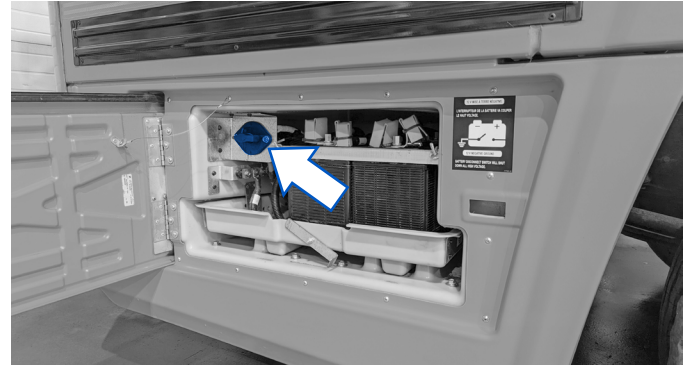

Figure 27 - Battery disconnect switch

DISABLING THE HIGH VOLTAGE

Double cut one of the cut loops (under the hood – **Figure 29** or in the fusebox compartment – **Figure 30**) will also disable the high voltage circuit.

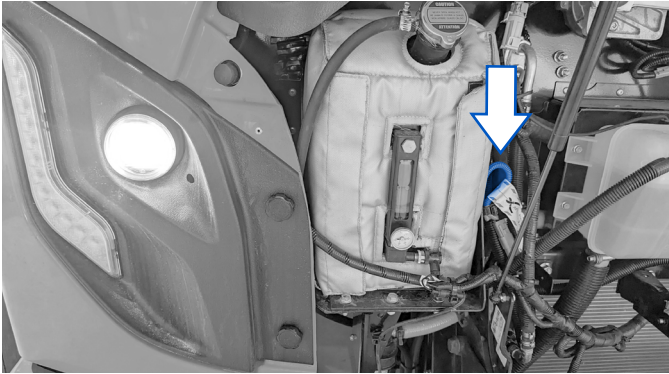

Figure 28 - Cut loop, under the hood.

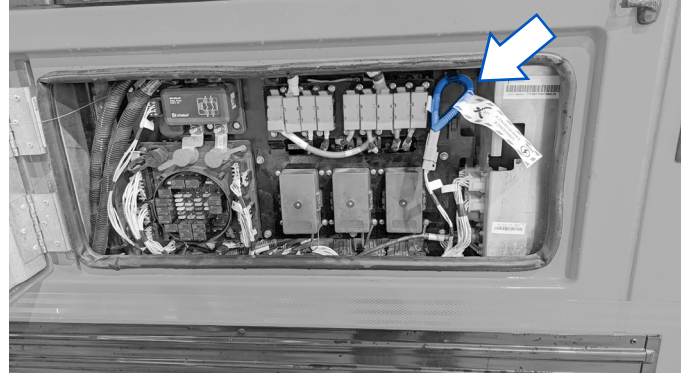

Figure 29 - Cut loop, fusebox compartment

Fire extinguishment of high-voltage batteries

If there is a crack in the batteries due to an impact, an inflammable and corrosive electrolyte solution may leak.

If there is a fire in the batteries, use a lot of water or dry ice (carbonic ice) to cool down the batteries. The batteries will not explode.

Depending on the availability, other extinguishing agents may also be used.

As common in firefighting, complete personal protective equipment (PPE) including self-contained breathing apparatus (SCBA) must be used.

If there is a fire that is not emerging from the high-voltage batteries, it can be treated using typical vehicle firefighting procedures. However, the High Voltage Battery outer shell should never be broken open to prevent a fire.

Submerged vehicle

A vehicle that is submerged in water will not present a risk of electrocution since the high-voltage batteries are isolated from the vehicle chassis. However, a submerge high voltage battery can catch fire.

Treat a partially or fully submerged LionD as any other vehicle and use the appropriate personal protective equipment (PPE).

Once the vehicle is removed from water, disable the high voltage using the procedure listed in this manual (**See page 19**).



If the vehicle has been immersed in water, turn the battery disconnect switch to the "OFF" position and contact your Lion Service Centre for instructions.

If the vehicle is parked indoors, it must be towed outside and parked away from buildings and other vehicles.

HOOD ACCESS

Hood

To open the hood:

1. Stand in front of the vehicle and locate the two release levers at the base of the hood. One is located directly below the center of the **LION** crest; the other one is located 15 cm to the left.
2. Pull both levers.
3. Lift the hood.
4. Two lift struts allows the hood to stay open.

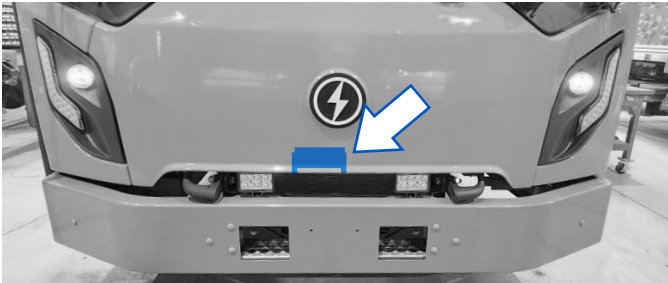

Figure 30 - Hood latches



Figure 31 - Latch opening

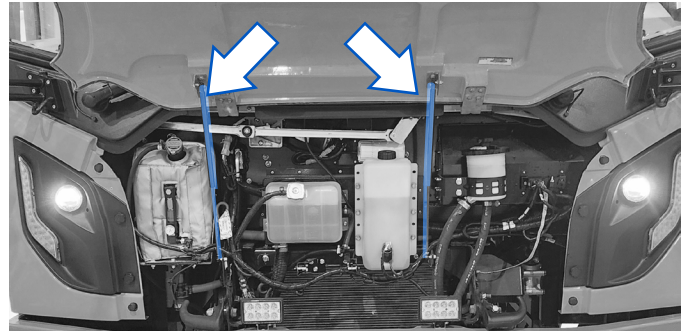

Figure 32 - Lift struts

Fluid tank locations

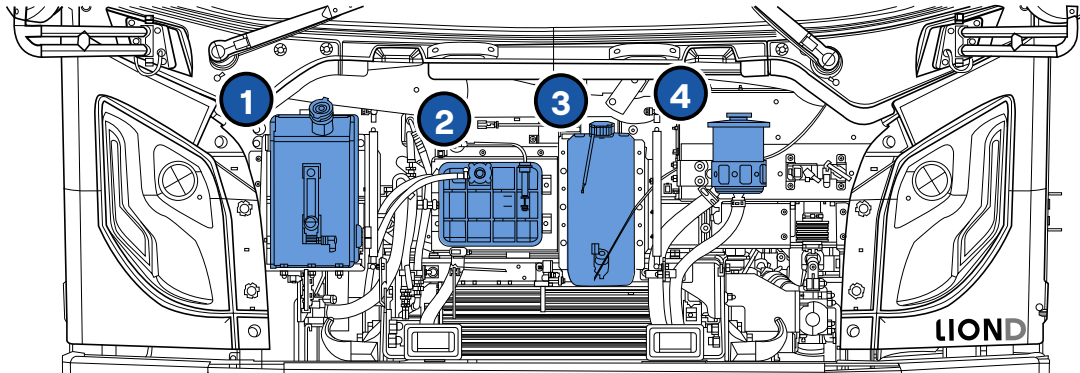

Figure 33 - Fluid tank locations

No.	Description	No.	Description
1	Heating system expansion tank (coolant)	3	Windshield washer fluid reservoir
2	Reservoir - powertrain cooling system (coolant)	4	Power steering hydraulic fluid reservoir

Table 2 - Fluid tank locations

RECOVERY AND TOWING

Recovery

This vehicle can be pulled or recovered on a very short distance by using the chassis tow hooks.

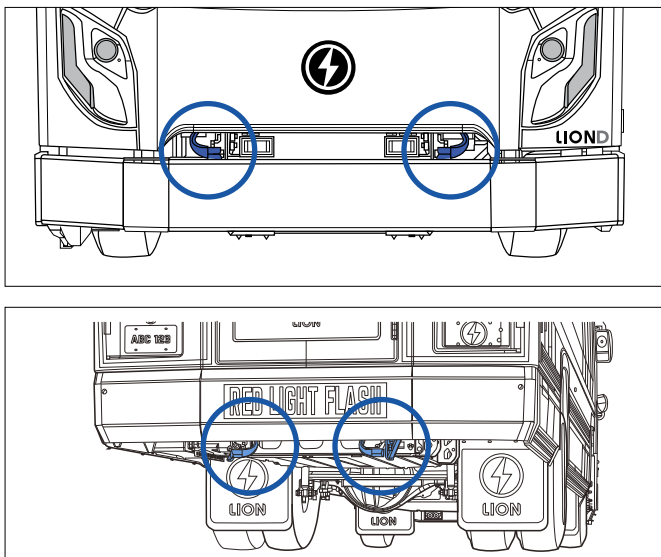

Figure 34 - Tow hooks

Towing

The front axle can't support the full weight of the vehicle. Hence, towing by lifting the rear wheels is prohibited. The recommended method is on platform towing (**Figure 35**).

Alternatively, it can be towed from the front axle with the rear wheels on the ground. However, the following points must be respected **AT ALL TIMES**:

- Both rear axle half-shafts must be removed.
- The parking brake must be manually released by inserting the release bolt ("caging bolt") into each rear brake chamber.



Figure 35 - Flatbed towing

In case of an emergency where it is not practical or too dangerous to remove the rear wheel half-shafts, it is possible to tow the vehicle on a short distance without removing them.

However, some parameters must be respected:

- The battery disconnect switch must be at "OFF".
- The towing speed must be slower than 20 km/h (12 mph).
- The towing distance can't exceed 10 km (6 miles).

The other instructions that apply when towing the vehicle with the rear wheel half-shafts removed are still valid:

- The parking brake must be released (or both brake chambers must be manually caged).
- The pneumatic suspension air tank must be connected to the towing vehicle air supply.

Then, when the vehicle is safely parked, the rear wheels half-shafts must be removed according to the normal towing procedure.

Preparation

1. Ensure the parking brake is applied, and the rear wheels are chocked.
2. Connect an external air supply to the air circuit quick-connect port located near the air dryer assembly and open the cut-off valve.

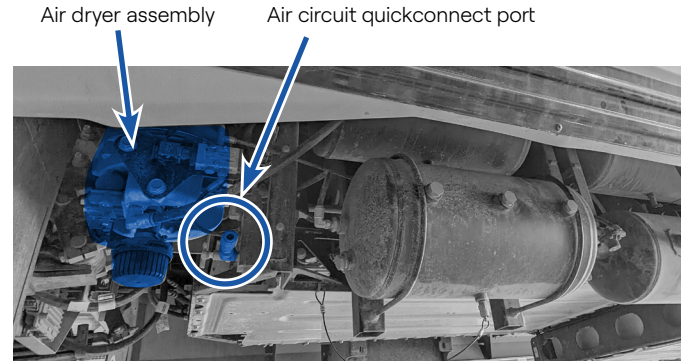

Figure 36 - Air circuit quick-connect port

TOWING THE VEHICLE

Preparation

1. Ensure the parking brake is applied, and the rear wheels are chocked.
2. Connect an external air supply to the air circuit quick-connect port located near the air dryer assembly and open the cut-off valve.
3. Allow air reservoirs to fill to at least 80 psi.
4. Position tow truck's crossbar and lift adapters beneath the vehicle's steer axle, ensuring the lift adapters are position directly beneath the suspension between the U-bolts (**Figure 37**).
5. Lift the tow truck's crossbar until the steer axle is seated on the lift adapters.
6. Secure the axle to the crossbar with chains or ratchet straps.



Figure 37 - Tow truck's crossbar and lift adapters



Figure 38 - Lion D lifted by the front axle

Half-Shaft Dismounting

Perform Half-Shaft Dismounting Procedure (**both wheels**):

1. Place a drip pan under the wheel hub on the driver's side.
2. Remove the 8 nuts securing the axle flange to the hub.
3. Remove the axle shaft by sliding it out from the center of the hub (**Figure 39**).
4. Install a suitable hub cover plate over the opening and reinstall fasteners to seal it (**Figure 40**).

Repeat steps 1 through 4 for the other rear wheel.

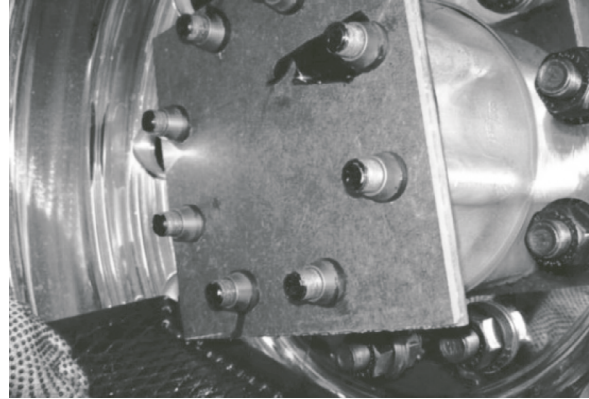

Figure 40 - Hub cover plate

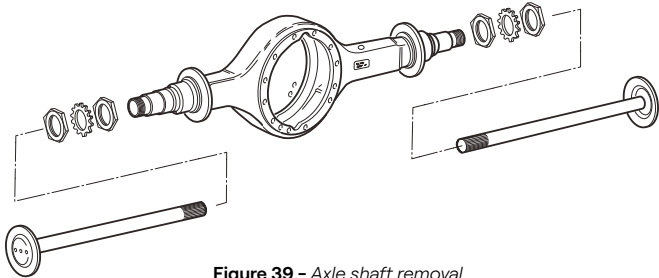

Figure 39 - Axle shaft removal

TOWING THE VEHICLE

Parking brake manual release

1. Disengage the parking brake from inside the cabin.
2. Remove the dust plug from parking brake chamber (Figure 41).

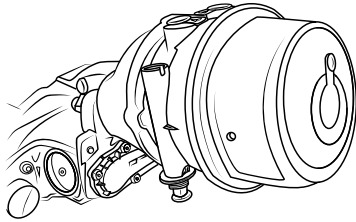

Figure 41 - Parking brake chamber

3. Remove the release bolt ("caging bolt") from its storage sleeve.
4. Insert the release bolt head through the opening in the brake chamber.
5. Turn release bolt clockwise (1/4 turn) to lock its head in the "T-slot" receptacle of the brake chamber (Figure 42).
6. Tighten the release bolt nut until the spring in the chamber is 90-95% compressed.

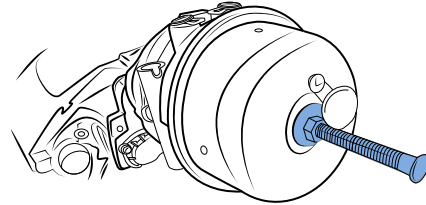

Figure 42 - Parking brake chamber

Finalization

1. Set the vehicle's Battery disconnect switch to "OFF".
2. Lift the vehicle's front end.
3. Remove wheel chocks.
4. Retract the recovery boom to position the vehicle into its final towing position.
5. Install towing safety chains.
6. If required, adjust the tow truck's boom height to limit the vehicle's height to less than 115 in.
7. The vehicle is now ready to be towed.

Preparing Vehicle for Road Use

Before the vehicle can be driven again, following actions must be completed.

1. The parking brake release bolts must be removed
2. The external air supply must be removed.
3. The axle shafts must be re-installed, and the differential oil topped up.

Parking Brake Release Bolts Removal

1. Disengage the Parking Brake.
2. Using a wrench, unscrew release bolt nut.
3. Replace the release bolt into its holder.
4. Re-install nut and washer and tighten to 10-15 lb-ft (14-20 Nm).
5. Replace the dust plug onto brake chamber, and ensure it is seated correctly.
6. Perform Steps I to V for the other brake chamber on the rear axle.
7. Apply the parking brake.

Axle Shafts Re-installation Procedure

1. Clean any debris off from the axle half shafts.
2. Reinstall axle half shaft into wheel hub housing with new gaskets (Lion PN: 11-14418-000).
3. Tighten nuts to 180 ft-lb (244 Nm).
4. Perform Steps 1 to 3 on the other side.
5. Rotate the wheel until the oil fill hole on the hub is facing up.
6. Remove the oil fill plug.
7. Pour 1/2 pint of axle oil into each hub.
8. Install oil fill plug and tighten to 40 to 60 ft-lb (54 to 82 Nm).
9. Place a drip pan beneath the rear axle's differential cover fill plug.
10. Ensure the differential oil is not too hot to touch.
11. Clean the filler plug and the area around it before unscrewing the filler plug.
12. Insert a finger and make sure the oil level is just beneath the filling port. If required, add oil.
13. Replace filler plug and torque to 40 to 60 ft-lb (54 to 82 Nm).

NOTES

NOTES

LIOND

THE LION ELECTRIC COMPANY

921 Rivière-du-Nord Road
Saint-Jérôme, Quebec CANADA J7Y 5G2
1-855-546-6706
Info@thelionelectric.com